

Guidance Note – Scaffolding Safety



Guidance Note – Scaffolds

Vedanta Limited

Sustainability Governance  
System

Guidance Note GN19

Scaffolding Safety

## Guidance Note – Scaffolding Safety



Guidance Document Title:	Scaffolding Safety	Date of Revision	25/04/2019
Document	VED/CORP/SUST/GN19	Revision:	V.0

Document Issue and Revision History		
DATE	REVISION NUMBER	CHANGE SUMMARY
25/04/2019	V0.	

Prepared by:	Sandeep Acharya
Signature	
Position:	Head – Safety & Occupational Health

Authorised by:	Phillip Turner
Signature	
Position:	Group Head – HSE & Sustainability

### Confidentiality

This document and its contents are the copyright property of Vedanta Resources Plc. The release of this document to any third party outside of Vedanta is strictly prohibited without prior consent.

1. INTRODUCTION	6
1.1. WHO IS THIS GUIDANCE NOTE AIMED AT?	6
1.2 WHAT IS THE AIM OF THIS GUIDANCE NOTE?	6
1.3 WHAT ISSUES DOES THIS GUIDANCE NOTE ADDRESS?	6
1.4 HOW SHOULD THIS GUIDANCE NOTE BE USED?	6
2. DEFINITIONS	7
3. ROLES AND RESPONSIBILITIES	15
4. GENERAL SAFETY REQUIREMENTS	17
5. COMMON TYPES OF SCAFFOLDS AND SPECIFIC REQUIREMENTS	18
6. SCAFFOLD PLANNING	25
7. ERECTING A SCAFFOLD SAFELY	29
8. SCAFFOLD STABILITY	38
9. SCAFFOLD WORK PLATFORMS AND ACCESSORIES	45
10. KEY HAZARDS AND COUNTERMEASURES	48
11. SCAFFOLD INSPECTIONS AND TAGGING	70
12. EMERGENCY RESPONSE, RESCUE AND RECOVERY	73
13. TRAINING, COMPETENCY AND AWARENESS	77
14. SUPPLIER AND CONTRACTOR MANAGEMENT	77
15. RECORDS	77
REFERENCES	78

## ANNEXURES



# Guidance Note – Scaffolding Safety

## 1. INTRODUCTION

### 1.1. Who is this Guidance Note aimed at?

This Guidance Note (GN) is aimed at all Vedanta subsidiaries, operations and managed sites, including new acquisitions, corporate offices and research facilities and to all new and existing employees and contractor employees. This GN is applicable to the entire operation lifecycle (including exploration and planning, evaluation, operation and closure). This GN is applicable to activities related to the management of scaffold and scaffolding equipment either owned by Vedanta or leased/hired through a third party.

### 1.2. What is the aim of this Guidance Note?

The aim of this Guidance Note is to outline the company requirements which Vedanta implements in order to prevent injuries and fatalities from:

- dropped objects;
- people falling from heights, and
- scaffold instability and/or collapse.

### 1.3. What issues does this Guidance Note address?

This document intends to address the following aspects:

- provide a framework which encapsulates the various elements of the scaffold lifecycle that should be considered by sites; and
- introduce a set of safety principles that can be used to guide the establishment of controls for the use of scaffold throughout its lifecycle.

### 1.4. How should this Guidance Note be used?

This Guidance Note is mandatory (as per instructions in Section 1.3 above) and is intended to provide a standard baseline and reflect good practice whilst providing the basis for continual improvement of sustainability issues across the Vedanta business. The need for flexibility at a site depending upon specific circumstances or regulatory specific requirements is also recognised. This Guidance Note is not designed to be definitive text, nor is it designed to provide prescriptive methods and procedures for undertaking tasks.

In certain cases there will be national and/or local regulatory requirements which address tasks involving scaffolding design, erection, use, repair, and dismantling sites shall ensure that these requirements are identified and complied with.

The successful implementation of this Guidance Note is expected to require dedicated commitment from all of the Vedanta sites.

2. DEFINITIONS

Term	Definition
Adjustable Leg/ Base Jack	A threaded bar or tube with nut designed to fit inside a standard to support the load from the standard. Used for levelling in conjunction with a baseplate, U-head or castor.
Anchorage	Anchorage means inserted in, or attached to, the structure for attaching a tie member. Note: the effect of an anchorage may be achieved by the tie being connected to a part of the structure primarily intended for other purposes.
Base plate	Base plate is a plate used for spreading the load in a standard (load bearing member) over a greater area/ supporting structure.
Bay length	The horizontal distance between two longitudinal-adjacent standards or the horizontal distance between support points on a suspended swinging stage.
Bay width	The horizontal distance between any two transversely adjacent standards or the width of a suspended swing stage.
Birdcage Scaffold	Birdcage scaffold is a scaffold structure comprising a grid of standards and a decked area usually intended to access a large area like a ceiling or for storage. It is an independent scaffold consisting of usually more than two rows of standards in both directions connected by ledgers and transoms.
Bridle	Bridle is a tube fixed across an opening or parallel to the face of a building to support the inner end of a transom or tie tube.
Box-tie	A tie assembly that is positively fixed to every side of a column or beam.
Brace	A member fixed diagonally to two or more members of a scaffold to provide rigidity to the scaffold and prevent distortion of scaffold.
Bracket	Engineer designed bracket that is attached to a structure to support a scaffold.

Bracing- Horizontal	Bracing in horizontal plane is an assembly of components that provides shear stiffness in the horizontal planes, e.g. by decking components, frames, framed panels, diagonal braces and rigid connections between transoms and ledgers or other items used for horizontal bracing. Also known as plan brace.
Bracing- Transverse	A brace in a plane that is vertical and at right angles to the building or structure (e.g. dogleg or parallel brace).
Bracing- Vertical/ Longitudinal	Bracing in vertical plane is an assembly of components that provides shear stiffness in the vertical planes, e.g. by closed frames with or without corner bracing, open frames, ladder frames with access openings, rigid or semi-rigid connections between horizontals and the vertical components, diagonal bracing, or other items used for vertical bracing. Longitudinal bracing is a type of vertical bracing
Castor	Castor is a swivelling wheel secured to the base of a vertical member for the purpose of mobilising the scaffold.

Term	Definition
Catch platform/ Screen	A platform/ screen attached to a scaffold, to contain falling debris.
Cladding	Cladding is a material normally intended to provide weather and dust protection, typically sheeting or netting.
Coupler	Coupler is a device used to connect two scaffold tubes.
Design	Design means conception and calculation to produce a scheme for erection of scaffold.
End-to-End Coupler	A coupler used to join two tubes end to end.



Frame Scaffold	A scaffold assembled from prefabricated frames, braces and accessories.
Gin Wheel	A wheel hung from a scaffold that a rope runs through to raise and lower materials.
Guardrail	Guard-rail is a member incorporated in a scaffold to prevent the fall of a person from a platform or access way.
Height of Scaffold	The vertical distance from the supporting structure to the highest working platform.
Ladder access tower	An independent scaffold bay attached to a scaffold with internal ladder access provided.
Ledger	Ledger is a horizontal member normally in the direction of the larger dimension of the working scaffold.
Lift	The vertical distance from the supporting surface to the lowest ledger of a scaffold or level at which a platform can be constructed. Or, the vertical distance between adjacent ledgers of a scaffold at which a platform can be constructed (average lift 2.0m).
Loading Bay	A platform on a scaffold for the storage of materials and plant. Also known as a loading platform.
Member	Anything that forms part of the scaffold assembly.
Mobile Scaffold	An independent freestanding scaffold that is mounted on castors.
Modular Scaffold	A prefabricated scaffold assembly with individual components, braces and accessories of set sizes.
Netting	Netting is a pervious cladding material.

Node	Node is a theoretical point where two or more members are connected together.
Term	Definition
Parallel Coupler	Parallel coupler is a coupler used for connecting two parallel tubes. Platform is one or more platform units in one level within a bay.
Platform unit	Platform unit is a unit (prefabricated or otherwise) that supports a load on its own and that forms the platform or part of the platform and may form a structural part of the working scaffold.
Putlog	A tube or other member spanning from a ledger to the wall of a building and which may have a specially formed end (Putlog end) which may be detachable) for the purpose of fixing into the brickwork (into the joints of the wall).
Putlog Coupler	A coupler for fixing a putlog to a ledger (single coupler).
Right Angle Coupler	Right angle coupler is a coupler used for connecting two tubes crossing at a right angle.
Sheeting	Sheeting is an impervious cladding material.
Slide/ Edge Protection	Side protection is a set of components forming a barrier to protect people from the risk of falling and to retain materials.
Operation(s)	A location or activity that is operated by a Vedanta Company and is part of the Vedanta Group. Locations could include mines, refineries, ports or transportation activities, wind farms, oil and gas development sites, offices including corporate head offices and research and development facilities.

Scaffold	<p>Scaffold means any temporary structure, including its supporting components, whether fixed, suspended or mobile, that is used—</p> <ul style="list-style-type: none"> <li>a) for supporting employees and materials, or</li> <li>b) to gain access to any structure, and includes a working platform, a working stage, a gangway, a run and a ladder or stepladder (other than an independent ladder or stepladder that does not form part of such a structure), together with any guard-rail, toe-board or other such safeguard and all fixings thereon, but does not include— <ul style="list-style-type: none"> <li>□ lifting equipment, or</li> <li>□ a structure used only to support another structure or equipment (including lifting equipment).</li> </ul> </li> </ul>
Sleeve Coupler	Sleeve coupler is a coupler used for joining two tubes located co-axially.
Sole board/ plate	Sole board/ plate is a member used to distribute a load through a baseplate to the supporting surface or supporting structure.

Term	Definition
Span	The distance measured along a member between the centre lines of support points (e.g., bearers supporting a scaffold plank).
Spigot	Spigot is an internal fitting to join one tube to another coaxially. Spigot pin is a pin placed transversely through the spigot and the scaffold tube to prevent the two from coming apart.
Spurred Scaffold	A scaffold that is partially supported by spurs (inclined load-bearing members that transmits a load to another structural member of the scaffold or to a supporting structure)

Stabilizer	A component that increases the effective base dimensions of a tower and is attached to a vertical load-bearing member.
Standard/ Upright	Standard is a vertical structural member that transmits a load to a supporting surface or foundation.
Sway Transom	Sway transom is a transom extended inwards in contact with a reveal or the side of a column to prevent the scaffold moving sideways.
Swivel Coupler	Swivel coupler is a coupler used for connecting two tubes crossing at any angle.
Tie Member	Tie member is a component of the scaffold that connects it with an anchorage at the structure.
Through-Tie	Through tie is a tie assembly through a window or other opening in a wall.
Toe-board/ Kickboard	Toe-board is an up-stand at the edge of a platform, intended to prevent materials or operatives' feet from slipping off the platform.
Transom	Transom is a horizontal member normally in the direction of the smaller dimensions of the working scaffold, which may also support a working platform.
Vessel Scaffolding	Scaffolding that is erected around a structure with a curved profile (e.g. a tank or chimney). It generally encompasses the entire face of the vessel.
Working area	Working area is the sum of the platforms in one level, which provides an elevated safe place for people to work on and to have access to their work.

**Work Platform**  
 Working platform means any platform used as a place of work or as a means of access to or egress from a place of work, including any scaffold, suspended scaffold, cradle, mobile platform, trestle, gangway, gantry and stairway that is so used.

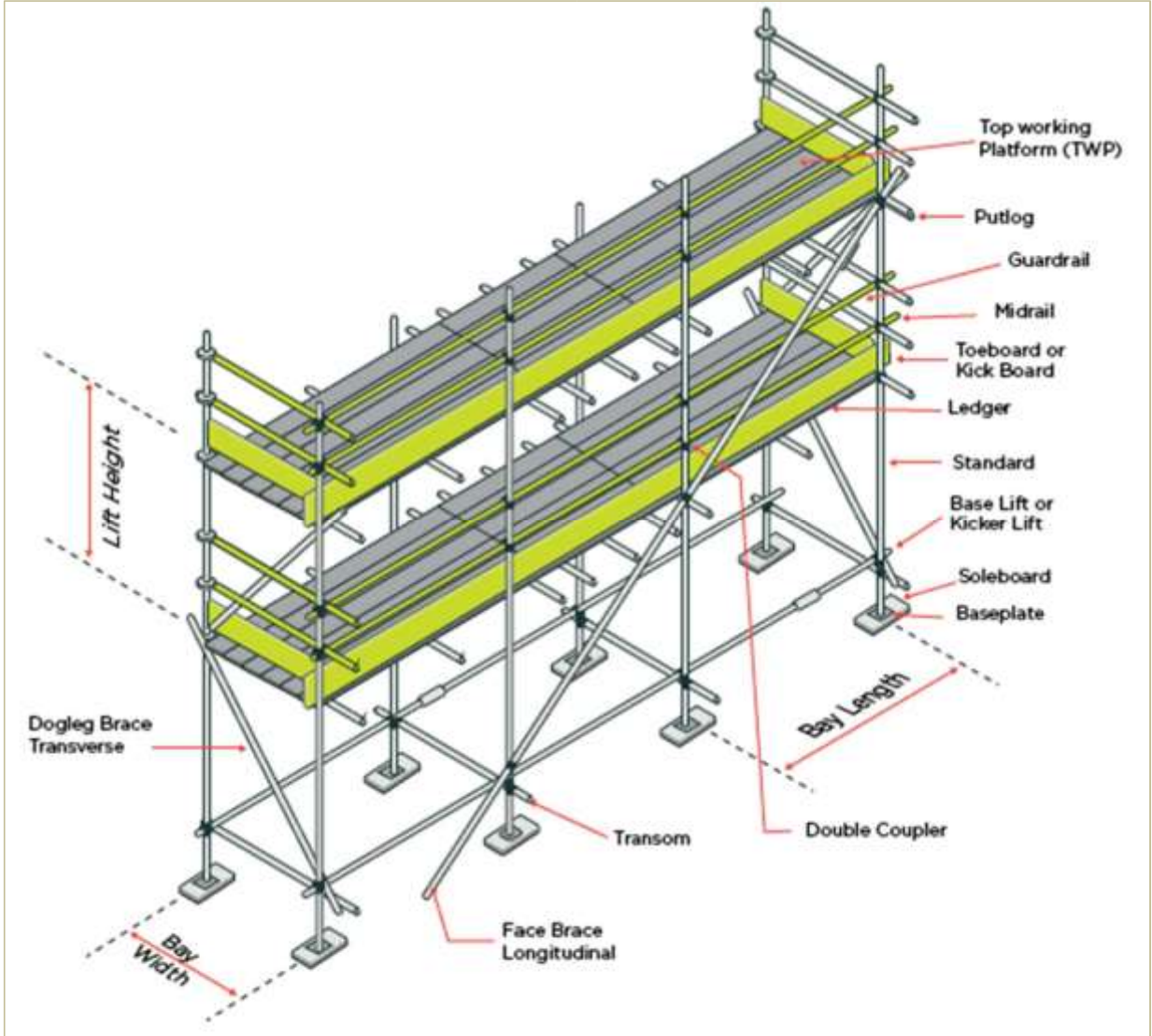

Figure 1: Key Components of a Double Pole Tube and Coupler (design) Scaffold

See Annexure A for more scaffold illustrations explaining other key scaffold components.



## 3. ROLES AND RESPONSIBILITIES

### 3.1 Site Leaders are responsible for:

- Providing necessary resources and personnel to support the effective implementation of the requirements outlined in this document within their respective locations;
- Planning the work and providing appropriate training for personnel erecting, using, inspecting or dismantling scaffolding.
- Ensuring that, where personal or collective protective equipment is required by the employee(s) to safely conduct the work, such equipment is available;
- Ensuring that scaffolds erected and used within their respective sites to provide working/ access platforms for workers comply with all applicable legal requirements and the requirements of this Guidance note (where corresponding requirements are either lacking or are less stringent under the local regulations).

Designers are responsible for undertaking design calculation and projects, prepare drawings and brief the team to communicate the design. Their duties include:

- Identifying any hazards that their design may present during construction and subsequent maintenance;
- Where possible, eliminating the hazards or reducing the risk;
- Communicating necessary control measures, design assumptions or remaining risks to the Project team so they can be dealt with in the Safety and Health Plan;
- Co-operating with other designers and the project team;
- Taking account of any existing safety and health plan or safety file; and
- Ensuring that the scaffolding project: is capable of being constructed to be safe, can be maintained safely and complies with all relevant health and safety legislation and the requirements under this guidance note.

### 3.2 Competent Person (for design verification of Scaffolds)- is a person who:

- Has been identified and designated (or approved, in case of external resource) by the Vedanta business leader(s) to be decision making authority/ expert in matters regarding the suitability, adequacy, and serviceability of scaffolding structures and work platforms to be used within Vedanta premises;
- Is responsible for advising the site scaffolding supervisors regarding the safe erection, modification, use and dismantling of and scaffolding structures and work platforms;
- Has the qualifications (e.g. registered professional engineer) and experience to structurally design and analyse the scaffolding configuration with respect to imposed and allowable loads (live, static and dead loads) and;
- Has the experience to consider a range of scaffolding systems and the strength and weakness for a particular configuration; and

Has the expertise to review the design adequacy and suitability of the Fall Arrest System selected for the scaffolding configuration or has the access to such expertise as necessary in the verification process.

### 3.3 Site (Scaffolding) Supervisors

They are qualified and competent personnel, designated by Site leaders at each Vedanta location, responsible for:

- consulting with the Competent Person(s) in matters regarding the safe erection, modification, use, inspection and dismantling of and scaffolding structures and work platforms;
- overseeing the erection, repair and dismantling operations of scaffold structures and temporary work platforms and ensuring that the same is implemented as per approved designs and work plans;
- ensure the workers erecting, using, inspecting or dismantling scaffolding are provided with appropriate training and required task protective or personal protective equipment to safely conduct the work.
- ensuring that all scaffolds and scaffolding components are inspected at the requisite frequencies as specified under local regulations and is provided with appropriate colourcoded (Green, Yellow or Red) tags at each point of entry, indicating its status and condition;
- the timely identification of defects in scaffolds (or components therein) or the development of hazardous conditions (storm, winds etc.) which could affect the structural integrity of scaffolds and the authorization of prompt corrective actions; and  Ensuring that the necessary fall prevention measures are implemented and used by (scaffolders and others) during erection, modification, use, and dismantling of and scaffolding structures and work platforms.

### 3.4 Authorized Scaffolders

Is an operative who is authorized by Vedanta in carrying out the erection, modification and dismantling of scaffolds (and associated structures) under the supervision of a competent person. Scaffolders should receive information, instruction, training and supervision in the safe erection, dismantling, maintenance and alteration of the scaffolding and should be competent.

They may be Vedanta employees or contractor workmen. In case external contractors are employed to carry out scaffolding works, the site should follow a certification and authorisation process to recognize them as Authorized Scaffolders after due training and verification.

### 3.5 Users of scaffold- must be trained and authorized to work at height. They must: Take reasonable care of their own safety and that of others while working on or near scaffolding structures and temporary work platforms and comply with instruction given;

- Ensure that the scaffold is not used unless a written confirmation (say, with Green Tags- Refer Section 11.2 for details) is received from a competent person (Scaffolding Supervisor), who has inspected the scaffold, that construction of the scaffold has been completed,
- Make effective use of personnel and collective protective equipment provided;
- Ensure that they do not make any unauthorized alterations or additions to the scaffold structure or configuration; and
- Report to their employer defects in the scaffold or in the system of work that may endanger health and safety; and not interfering with or misusing the scaffold.



### 4. GENERAL SAFETY REQUIREMENTS

- The preferred system of scaffold is modular; and tube and coupler.
- The use of ALL other scaffold systems must be subject to a detailed risk assessment and must be approved by the Site Leader.
- The use of bamboo or timber structures is NOT permitted within Vedanta premises. [Note: However, the use of scaffold grade wooden planks is, permitted, provided their use is duly approved in writing by the Vedanta designated Competent Person].

#### 4.1 Applicable to all Scaffolds

- Each scaffold and scaffold component must support without failure its own weight and at least four (04) times the maximum intended load applied or transmitted to it.
- Scaffolds must only be loaded in accordance with the manufacturers' specifications or the design approved by a competent person. Scaffolds and scaffold components must not be loaded in excess of their maximum intended loads or rated capacities, whichever is less.
- Every scaffold and every part thereof including supports shall be of good construction, suitable and sound material and having adequate strength for the purpose for which it is used.
- Construction and dismantling of every scaffold shall be under the supervision of a competent person thoroughly experienced in this work.
- Scaffold must be aligned, levelled, and straight.
- The area around the scaffold should be isolated and marked off;
- Every scaffold shall be securely supported or suspended and shall, where necessary, be sufficiently and properly strutted or braced to ensure stability. All scaffolds (except mobile scaffolds, suspended scaffolds and hung scaffolds) should have support bases;
- The work level shall be planked or decked as fully as possible with deck planks or metal trays, which should be fastened on its surface (see details in Section 9.1).
- Each supporting member used in the construction of runways, platforms, ramps and scaffolds shall be securely fastened and braced.
- All scaffolds or working platforms shall be securely fastened to the building or structure; if independent of the building, they shall be braced or guyed properly. All fasteners and anchorages shall be inspected by a competent person (see Section 9.1 for details).
- Safe and adequate means of access and egress should be provided and maintained for scaffolds (see Section 10.2.3 for details).
- No one shall be allowed to work from scaffolds during storms or high winds.
- After heavy rains or storm, the scaffolds should be inspected by the competent Scaffolding Supervisor. Where the joints or members are found defective, the joint should be set right and member replaced.
- In case both light and heavy duty scaffolds (See Section 9.1 for duty ratings) are used in close vicinity, conspicuously placed notice boards shall indicate the light duty scaffolds and the limits on their usages.

## 5. COMMON TYPES OF SCAFFOLDS AND SPECIFIC REQUIREMENTS

### 5.1 Frame Scaffolds/ Tube and Coupler Scaffolds

The design, installation, use and dismantling of such scaffolds should meet applicable local regulatory requirements. In addition to the requirements specified in Section 5.1, the following requirements also apply:

- A design project and calculations should be developed for all scaffolds with heights greater than 6 feet. Such projects should specify considerations for both assembly and dismantling stages.
- A standard design (maximum load and drawing- usually supplied from the manufacturer) is required for frame scaffolds that will hold people and are 4 times higher than the smaller size of the base width. For heights higher than the mentioned above, a project design as well as calculations will be required.
- The scaffold must be equipped with guardrails and toe boards installed up to the height of the work along all open sides and ends. The guardrails and toe boards must be of regulation size as defined in this document.
- The scaffold should be near enough to the work to prevent people or materials from falling through the gap.

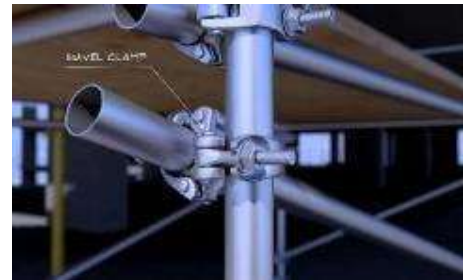

Figure2: Tube&CouplerScaffold

### 5.2 Facade Scaffolds

Should meet same requirements under Section 5.1 and those applicable to Frame Scaffolds or Tube and Coupler Scaffolds. Additional requirements for façade scaffolds are listed below:

- The vertical movement of parts and materials for assembly and disassembly should be made with ropes or a hoisting system;
- Access to facade scaffolds should be made through a ladder attached to the scaffold structure or through an access tower;
- Facade scaffolds used on jobs with a possibility of materials being thrown away at a distance should be equipped with guards made of mesh or a similar material from the first work platform up to at least 6 feet above the tallest work platform;
- The locking devices must be fastened correctly according to the manufacturer. No homemade or otherwise unapproved devices are allowed;

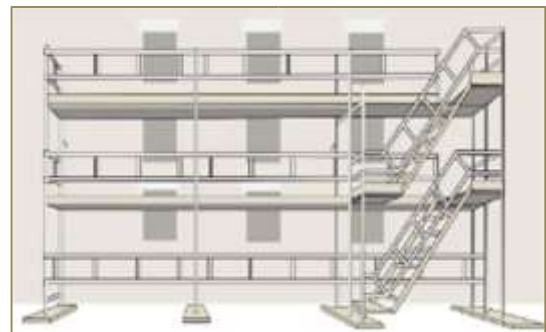

Figure3: FacadeScaffold

## Guidance Note – Scaffolding Safety

- Facade scaffolds should not have casters.

### 5.3 Birdcage Scaffolds

A birdcage scaffold is an independent scaffold consisting of more than two rows of standards in both directions and is connected by ledgers and transoms. It is mainly used for work carried out on a single level, for example ceilings. The following risk control measures should be implemented for birdcage scaffolds made from tube and coupler scaffolding:

- Observe compliance with requirements of Section 5.1 and those specified for tube and coupler scaffolds.
- See the designer's specifications when erecting and dismantling modular birdcage scaffolds.
- Only use birdcage scaffold to support formwork if it has been specifically designed for this purpose.
- Provide longitudinal bracing or a tied face at every third longitudinal row of standards.
- Brace the outside row of standards on each face and each 3rd row internally with longitudinal bracing.
- Provide transverse bracing at every fourth bay on the ends of the scaffold.

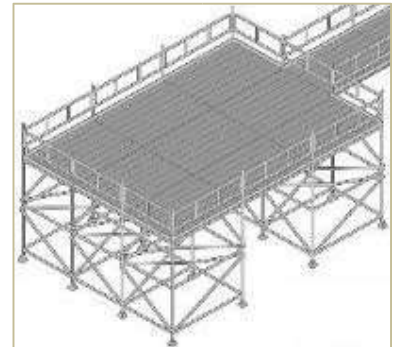

Figure4: BirdcageScaffold

### 5.4 Tower Scaffolds

A tower scaffold is an independent scaffold consisting of four vertical standards connected longitudinally and transversely or two frames in plan connected transversely to create a scaffold of one bay.

The following control measures should be implemented for tower scaffolds:

- Construct with modular, frame or tube and coupler scaffolding.
- Ensure the tower is resting on firm level ground with the feet properly supported. Do not use bricks or building blocks to take the weight of any part of the tower.
- Ensure the height of a tower scaffold from the bottom of the scaffold to the working surface is no greater than the multiple (usually 3 or 4) of the minimum base dimension as specified in the manufacturer, supplier or designer information.
- Reduce height to base ratios or provide extra support if the scaffold is:
  - Sheeted or likely to be exposed to strong winds;
  - Loaded with heavy equipment or materials;
  - Used to hoist heavy materials or support rubbish chutes;



Figure5: TowerScaffold

- Used for heavy or awkward operations, say, grit blasting or water jetting; a □ Supporting a ladder/ stairway.

### 5.5 Mobile Scaffolds

A mobile (or castor) scaffold is a tower scaffold mounted on castors/ wheels. Information about how to use and erect mobile scaffolds safely should be obtained from the manufacturers and/ or suppliers at the time of procurement. No alteration of a mobile scaffold is to be carried out without the guidance of manufacturer or supplier.

- Prefabricated mobile scaffolds should be erected in accordance with manufacturer's specifications.
- The height of a mobile scaffold—from the bottom of the scaffold to the working surface—should be no greater than the “multiple” (typically 3 or 4) of the minimum base dimension as specified in the manufacturer, supplier or designer information.
- Working from a mobile scaffold should not take place on balcony ledges, live edges and balconies unless the scaffolding is fixed to the structure, for example with screw jacks firmly secured to soffit.
- Where adjustable castors are used the slope of the surface should not exceed 5 degrees.
- Use a secure internal ladder with a protected opening (e.g. a hinged trap door for entry and exit to and from the scaffold).
- Select the correct size and capacity castors to support the total mass of the dead and live loads of the scaffold.
- Use castors that have the Working Load Limit (WLL) clearly marked.
- Castors fitted to standards should be locked before erection continues.
- Castors with adjustable legs should be used and adjusted to keep the platform level when the supporting structure is at different heights.
- Incorporate plan bracing at the base of mobile scaffolds to provide greater stability.
- Ensure guardrails, mid-rails and toe-boards are installed on working platforms.
- Caster scaffolds are only allowed on flat surfaces and they must have wheel lock devices.



Figure 6: Mobile/ Castor Scaffold

Before (and while) moving mobile scaffolds ensure that:

- there are no power lines or other overhead obstructions;
- the ground is firm and level;
- no personnel is on the scaffold;
- no equipment and material can be dislodged from the platform;

- the supporting surface is free of obstructions—a small obstruction may cause a mobile scaffold to overturn;
- electrical equipment and leads cannot be tangled;
- brakes on castors should be locked at all times unless moving the scaffold;
- the scaffold is not moved in windy conditions; and
- the mobile scaffold is either pushed or pulled from the base - never use powered vehicles to move the scaffold.

If a mobile scaffold is to be lifted using a crane, sling the scaffold at the point most likely to maintain stability and prevent dislodgment of scaffolding components. A crane should not be used to lift aluminium mobile scaffolds because the scaffolding components may fail. When lifting a scaffold using a crane, a lifting plan should be put in place outlining safe lifting points and how loose components like base jacks should be secured. The load should be slung by a competent rigger and manoeuvred in a way that ensures the load remains stable.

### 5.6 Suspended Scaffolds

- The anchorage and support systems and the support structures of the suspended scaffolds should be implemented with a previous project and calculations made and followed by a duly qualified professional;
- The installation and maintenance of suspended scaffolds should be made by an authorized scaffolder worker under the supervision and technical responsibility of a Competent Person following the manufacturer's technical specifications;

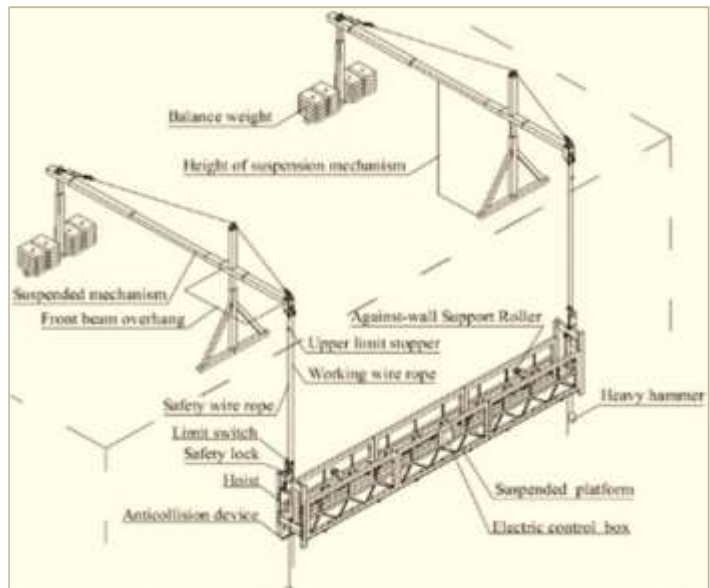

Figure 7: Suspended Scaffold and Components

- Suspended scaffolds should have an identification plate placed at a visible spot indicating the maximum allowed workload;
- Only suspended platforms with a double support system should be used;
- The stability of suspended scaffolds should be guaranteed at all times while it is being used through operating procedures and specific devices or equipment for this purpose;
- All suspension scaffold support devices, such as outrigger beams, cornice hooks, and parapet clamps, must be capable of supporting, without failure, their own weight and at least 4 times their maximum intended load;



- Scaffold support systems cannot be fixed with the use of sand bags, stones or any other type of counterweight;
- Natural or artificial fibre cables cannot be used to support suspended scaffolds, steel wire cables must be used;
- The steel cables of suspended platforms should be protected against sharp edges or other surfaces that cause friction;
- The length of the steel cables used in the ratchet hoists should be such that in the lowest position at the platform at least 6 (six) loops on every drum are still left;
- Swing sections cannot be added to the platform in suspended scaffolds;
- Suspended scaffolds cannot be connected for the movement of people or to perform tasks;
- Only material for immediate use can be placed on the suspended scaffolds;
- Scaffolds must be equipped with guardrail and toe board all around its sides with the proper size to prevent people and objects from falling, the guardrails and toe boards must be of regulation size as defined in this document.
- Counterweights used to balance adjustable suspension scaffolds must be able to resist at least four times the tipping moment imposed by the scaffold operating at either the rated load of the hoist, or one-and-a-half (minimum) times the tipping moment imposed by the scaffold operating at the stall load of the hoist, whichever is greater.
- Workers must wear a safety harness connected to the fall-arrest device, connected to a lifeline (one for each operator) attached to a structure that is not connected to the same support structure of the suspended scaffold;
- When lanyards are connected to horizontal lifelines or structural members on a singlepoint or two-point adjustable suspension scaffold, the scaffold shall be equipped with additional independent support lines and automatic locking devices capable of stopping the fall of the scaffold in the event one or both of the suspension ropes fail. Independent support lines shall be equal in number and strength to the suspension ropes.
- Vertical lifelines, independent support lines, and suspension ropes shall not be attached to each other, nor shall they be attached to or use the same point of anchorage, nor shall they be attached to the same point on the scaffold or personal fall arrest system; and
- When horizontal lifelines are used, they shall be secured to two or more structural members of the scaffold, or they may be looped around both suspension and independent suspension lines (on scaffolds so equipped) above the hoist and brake attached to the end of the scaffold. Horizontal lifelines shall not be attached only to the suspension ropes.

### 5.7 Temporary Fixed Platform or Hung Scaffolds

- Anchorage, support systems and the work platform structure should be installed and used only with an approved design project and calculations made and followed by a duly qualified professional.
- Installation and use under the supervision of a competent person only;
- Each scaffold and scaffold component shall be capable of supporting, without failure, its own weight and at least 4 times the maximum intended load applied or transmitted to it.
- Do not bridge between independent Hanging Scaffolds unless specifically designed for this purpose.
- The scaffold shall be secured against all anticipated sway and uplift forces. Vertical diagonal bracing shall be installed to prevent swaying. Horizontal diagonal bracing shall be installed as necessary to square the scaffold and provide additional rigidity.
- When overhead structural beams are used to support the hanging scaffold, either specialty scaffold beam clamps shall be used or the supporting overhead structural beam may be “boxed” using tubes and right angle clamps.
- Horizontal tubes resting directly on structural beams may be used for attaching hanging legs where the scaffold is lightly loaded and the hanging legs are directly adjacent to the supports for the horizontal tubes (scaffolds with no more than one work level and no more than two workers) unless designed by a registered professional engineer
- Platforms should be equipped with an identification sign placed at a visible spot indicating the maximum allowed workload;
- They must be equipped with guardrail and toe board all around its sides with the proper size to prevent people and objects from falling and resistant flooring without any opening, sized like item about guardrails and toe board of this protocol;
- The installation of other devices, such as hoists and pulley for the suspension of loads should be approved during the design stage.

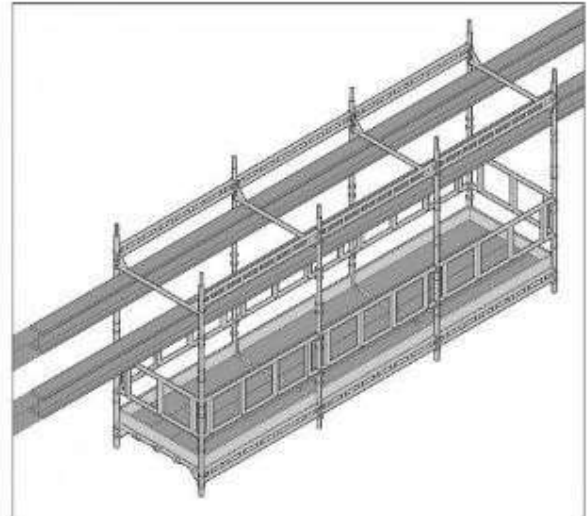

Figure8: HungScaffold

### 5.8 (Proprietary) System Scaffolds

Sometimes referred to as modular scaffolding, systems scaffolding consists primarily of vertical and horizontal pre-engineered components that connect together in a systematic fashion. Systems scaffolding is likely the most used type of scaffolding across the globe and there are hundreds of manufacturers, each having specific efficiencies. Some perform well in very highly loaded conditions and others are more suited to smaller repeated scaffold structures. Systems scaffolding is an umbrella term that includes many different types of scaffolding that can be used to create standardized scaffolding bays.

Some of the most popular types of systems scaffolding are given in Annexure B:

Irrespective of the type/ system used, whenever system scaffolding is used; it must be ensured that

- it is erected, altered and dismantled in accordance with the manufacturers' instructions for safe use;
- due attention is given to the use of suitable anchor positions for personal fall arrest equipment when applying the principles of this guidance; and
- scaffolders receive necessary information, instruction, training and supervision in the safe erection, altering and dismantling of the proprietary system scaffolding used, in accordance with the manufacturers' instructions.



## Guidance Note – Scaffolding Safety

### 6. SCAFFOLD PLANNING

Scaffolding work should be carefully planned in consultation with all relevant people involved in the work before work starts so it can be carried out safely. Consultation should include discussions on the:

- Ground condition and type,
- Weather conditions,
- Nature of the work and other activities that may affect health and safety,
- Working environment and interaction with other activities/ jobs,
- Access and egress from the scaffold,
- Management of mobile equipment and surrounding vehicular traffic; and  Safe Work Method Statements (SWMS)/ task based risk assessment.

#### 6.1 Risk Management

Tasks that have a Scaffolding aspect to them shall be risk assessed before they are conducted. A Job Safety Analysis (JSA) or equivalent can be used for this purpose.

This assessment should be documented and included in the work permit. The Safe Scaffolding Checklist (see Annexure C) should be used in conjunction with the risk assessment process to help identify the relevant risks.

#### Hierarchy of Controls

Controls can be ranked from the highest level of protection and reliability to the lowest. This ranking is known as the hierarchy of controls.

Elimination of a risk is the most effective control. Employers must always eliminate a risk if this is reasonably practicable. If this is not reasonably practicable, BUs must minimise the risk so far as is reasonably practicable by one or a combination of the following:

The risk assessment should take into account the following, as a minimum:

- Fall hazards
- Fall of materials
- Detrimental weather (high winds, storm etc.)
- Collisions with powered industrial vehicles,
- Electrical hazards
- Piping systems,
- Hot surfaces, floor resistance and stability, etc.

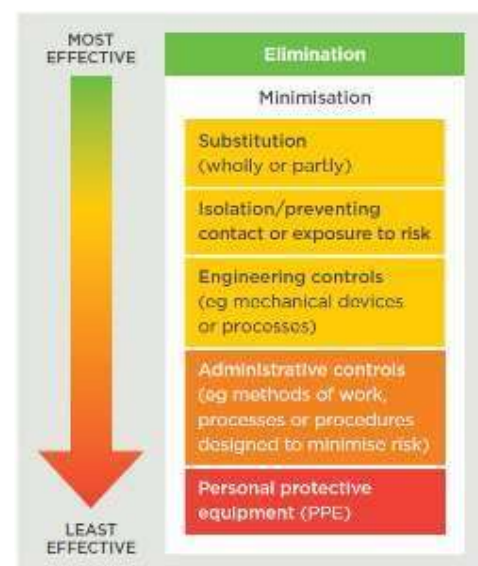

## Guidance Note – Scaffolding Safety

**Substitution:** For example, using elevating work platforms (EWPs) when erecting scaffolding over a void instead of working from the unfinished scaffold and using fall arrest equipment.

**Isolation:** Isolate means preventing contact or exposure to the risk. For example, using barriers to keep pedestrians away from the work.

**Engineering based controls:** For example, advance guardrail systems to provide edge protection while the scaffolder installs the guardrails.

**Administrative controls:** These may be employed, in order to minimize remaining risk (if any), so far as is reasonably practicable, for example by installing warning signs near the scaffolding.

Minimise any remaining risk with suitable Personal Protective Equipment (PPE). PPE such as harness, hard hat and safety footwear must be used at all times during the erection, alteration and dismantling of scaffolding.

### 6.2 Scaffolding Plan/ Safe Work Method Statement

As an outcome of the risk assessment process, a written Safe Work Method Statement along a scaffolding plan should address the following aspects:

- Basis of design,
- Type of scaffold,
- Foundations including ground conditions,
- The weight bearing capacity of the surface where the scaffold is to be erected,
- Dead loads e.g. resulting from the size and weight of the scaffold,
- Live and environmental loads e.g. wind loads,
- Containment sheeting,
- Supporting structure,
- Entry and exit,
- Tying and anchors— type and location of anchors on the supporting structure;  Bracing and guying, and  Edge protection.

### 6.3 Scaffold Layout and Design

Scaffold designers should consider the work practices necessary to erect and dismantle the scaffold as designed and identify health and safety risks and control measures at the design stage.

Designers should consider:

- The method and sequence of erecting and dismantling the scaffold and the related risks e.g. manual handling, exposure to fall hazards, overloading etc.
- Providing safe entry to and exit from work areas on and around the scaffold,
- Minimising the working heights for people erecting and dismantling the scaffold,

- Installing edge protection including guardrails, mid-rails and toe boards, containment sheeting, fall arrest systems e.g. horizontal life lines or other fall risk controls when working at height,
- Providing advice and information about using the scaffold e.g. drawings, scope of work instructions and bills of quantity to the scaffolding contractor and the principal contractor, and,
- Minimising sloping surfaces on a scaffold that may cause slip hazards and ensure risk control measures are identified and included in the design.

The design of the scaffold should also take into account:

- strength, stability and rigidity of the supporting structure,
- intended use and application of the scaffold,
- safety of people who erect, maintain, alter and dismantle the scaffold,  safety of people using the scaffold, and  safety of people near the scaffold.

**Scaffold Layout:** A well laid-out scaffold will require the minimum amount of modification during its life and will be capable of being erected, used and dismantled in safety. The initial layout will have a significant impact upon the safety of the completed scaffold.

When considering the layout the following points should be remembered.

- The scaffold should be laid out so as to reduce the gap between the structure and the scaffold to a minimum, except where guard-rails will be erected adjacent to the structure.
- The standards should be positioned so as to avoid manhole lids or shallow drains, which may not be able to sustain the scaffold loading.

**Structural Design of Scaffolds:** Strength and stability calculations for scaffolding should be carried out unless:

- a record of the calculations covering the structural arrangements contemplated is available; or
- the scaffolding is to be assembled in conformity with a generally recognised standard configuration (supplied by the manufacturer/ supplier).

### 6.4 Loading

- A scaffold should be designed for the most adverse combination of dead, live and environmental loads that can reasonably be expected during the period the scaffold is in use.
- The specifications of the designer, manufacturer or supplier should be followed for the maximum loads of the scaffold. The dead, live and environmental loads should be calculated during the design stage to ensure the supporting structure and the lower standards are capable of supporting the loads.
- Consider environmental loads, particularly the effects of wind and rain on the scaffold. For example, environmental loads imposed by wind and rain may be heightened if perimeter containment screens, shade cloth or signs are attached to the scaffold. Staggering the joints in standards may help control the risk of scaffold collapse from environmental loads.
- Dead loads relate to the self-weight of the scaffold structure and components including working, catch or access platforms, stairways, ladders, screens, sheeting, platform brackets, suspension ropes, secondary ropes, traversing ropes, tie assemblies, scaffolding hoists or electrical cables.

- Live loads include- Weight of people, Weight of materials and debris, Weight of tools and equipment, and Impact forces.
- Scaffolds **MUST NOT** be used to support formwork and plant (e.g.: hoist towers, concrete pumping equipment etc.) unless the scaffold is specifically designed for this purpose.

## 7. ERECTING A SCAFFOLD SAFELY

This section covers general methods and principles for erecting scaffolding (many also apply to dismantling). These are particularly relevant to tube and coupler (also known as tube and coupler) scaffolding systems, which are generally not covered by manufacturer's specifications and can be erected in many different configurations.

### 7.1 Before You Start

- Planning how to erect a scaffold is the first step to ensure the work can be done safely.
- Develop and follow a methodical work sequence—e.g. in a SWMS or scaffolding plan.
- Do not mix scaffolding from different manufacturers, unless a competent engineer approves that:
  - the components are of compatible size, strength and deflection characteristics;
  - the fixing devices are compatible; and
  - the mixing does not lessen the strength, stability, rigidity or suitability of the scaffold.
- Isolate the work area using, for example, diversion barriers.
- Where possible the scaffolders must:
  - erect the scaffold at 1 metre increments;
  - maintain no less than two planks wide; and
  - provide edge protection at each level where there is the potential to fall to a lower level.
- Make sure the stability of the ground is known.
- Decide how the scaffold will be kept stable, upright and free from undue movement. This may influence the design of the scaffold base so must be done early in the process. Use suitable sole-boards and baseplates.
- When installing or erecting scaffolds over or beside water, risk controls may include alternative erection methods, for example prefabrication away from the water and installation by crane.
- If the scaffold is erected adjacent to or over public spaces or adjoining property specific controls like hoardings, catch fans or barricades with clear signs should be provided. Catch platforms should be designed to support a uniformly distributed load of not less than 5 kPa.
- When working with scaffolding equipment the scaffolder should clearly mark defective equipment with paint or tags so defective equipment is identified and removed.
- Check live loads arising from the work of erecting or dismantling the scaffold are within the specification for the final design—the number of workers on the scaffold at any one time may need to be limited.

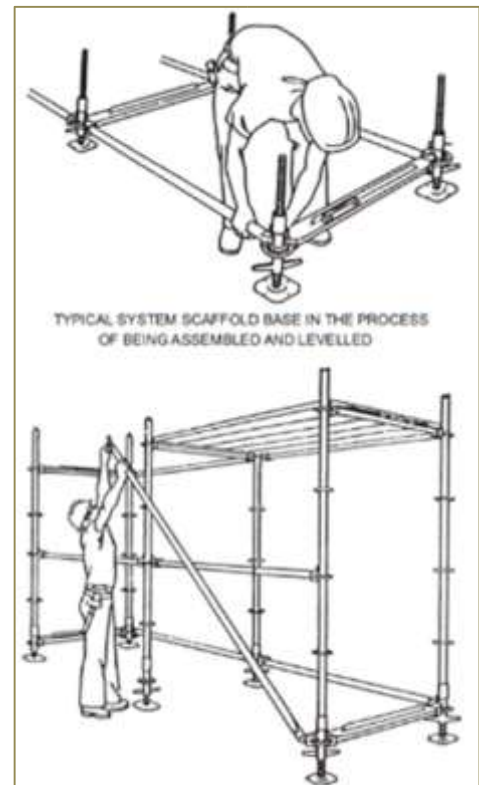

Figure 9: Typical Scaffold Erection Sequence

## Guidance Note – Scaffolding Safety

### 7.1 Unauthorised Access

- It must be ensured that unauthorised access to the scaffold is prevented while the scaffold is incomplete or unattended.
- This applies to suspended, cantilevered, spur or hung scaffolds, as well as a scaffold from which a person or thing could fall more than 4 metres.



Figure 10: Access Control Measures on Scaffold

- Entry to scaffold areas should be restricted to those carrying out the scaffolding work while the scaffold is being erected, altered, repaired or dismantled. Control measures, for example barriers and warning signs should be used to prevent unauthorised access when it is left unattended.
- Where a scaffold is left incomplete, there is a risk that it will be used while it is in a dangerous condition. To prevent this, where a scaffold is partly erected or dismantled, a prominent warning notice (or Tags) should be placed at each potential access point and barriers should be placed to prevent access. Such notices should be removed (only by a competent Scaffolding Supervisor) when they are no longer required.
- The most effective way of preventing access to an incomplete scaffold is by removing all decking and ladders. Incomplete scaffolds should be completed or dismantled as soon as practicable.

### 7.2 Adjacent Buildings or Structures

No part of the scaffolding activities should adversely affect the structural integrity of other buildings. Ensure risks are controlled to prevent injury to people or damage to adjacent buildings or structures from the:

- Collapse of the scaffold onto the adjacent building or structure, and
- Collapse of the adjacent building or structure, or a part of the building or structure.

### 7.3 Supporting Structures

- Consider the capability of the supporting structure to bear the most adverse combination of loads possible when using the scaffold. Get advice from a competent person before erecting scaffolds on verandas, suspended flooring systems, compacted soil, parapets and awnings.
- Propping/ additional support may be required where the supporting structure is not capable of bearing the most adverse combination of loads. Front-end loaders, forklifts, or pieces of equipment shall not be used to support scaffolds.



- Scaffolds shall not be hung from or supported by guardrails or handrails. A crane or other lifting device shall not lift any scaffold.

## 7.4 Foundations

- Scaffold foundations should be designed and constructed to carry and distribute all the weight of the scaffold including dead and live loads, for example perimeter containment screens placed on the scaffold.
- Foundations shall be sound, rigid, and capable of carrying the scaffold selfweight plus the maximum intended load without settling or displacement. Unstable objects such as barrels, boxes, loose brick or concrete blocks shall not be used to support scaffolds, planks, or timber sills.
- Ground conditions, the effects of the weather—particularly wind and rain—and loadings should be considered when designing the scaffold foundation.



Figure 11: Unsuitable bases supports

- When a scaffold is erected on a surface it is important that the surface is stable to bear the most adverse combination of dead, live and environmental loads that can reasonably be expected during the period the scaffold is in use.
- Water and nearby excavations may lead to soil subsidence and the collapse of a scaffold. Any likely watercourse, for example a recently filled trench which has the potential to create a wash out under the scaffold base should be diverted away from the scaffold.
- Competent person and scaffolding supervisor (preferably along with a competent civil engineer) should ensure ground conditions are stable prior to start of work. The ground or floor on which a scaffold stands shall be carefully examined for its load-bearing capacity. Sand or made-up ground (fill) may need compacting to ensure there are no cavities. Such bases as floors, roofs, etc., may need shoring from underneath.
- Scaffolders must be informed of factors which may affect ground stability before the scaffold is erected.

## 7.5 Sole-boards and Baseplates

- Sole-boards and baseplates can be used to evenly distribute the load from the scaffold to the supporting surface (see Figure 1). Both sole-boards and baseplates may be required for use on less stable surfaces, for example soil, gravel, fill or other product which creates a system of beams and flat slabs.
- Timber sills (sole boards) at least 225 mm (9 inches) wide by 38 millimetres (1-1/2 inches) thick shall be used to spread the load on sand, made up ground, asphalt pavement, wooden floors, and other soft or slippery surfaces, after making the ground level and compact.
- A sill shall extend under at least two posts (standards), unless not feasible because of uneven or sloping ground. In this case, sills under



Figure 12: Screw Jack

individual posts (standards) shall be at least 765 mm (30 inches) long. Scaffold planks shall not be used as sills.

- All scaffold posts (standards) shall be pitched on steel base plates at least 150 millimetres (6 inches) by 150 millimetres (6 inches) and 6 millimetres (1/4-inch) thick.
- Timber sills shall be used where base plates may be exposed to corrosive materials.
- Screw jacks shall be used in accordance with the manufacturer’s specifications to compensate for variations in ground level. Screw jacks shall not be adjusted to more than two-thirds of the total length of the threaded section.

## 7.6 Scaffold Tubing and Fittings Specifications

Scaffold tubing and fittings shall meet applicable code specifications and legal requirements (where available). Where there are no national codes on this topic, the following shall apply: □ It is recommended that tubing shall be 48.3 mm (1.9 inch) nominal outside diameter.

- Scaffold tubing (for tube-and-coupler, system, and fabricated tubular frame scaffolds, etc.) shall be welded or seamless structural steel pipe fabricated in accordance with any of the following pipe fabrication specifications and as specified in this section:

- ASTM A500, Grade B; 290 N/mm<sup>2</sup> (30 kg/mm<sup>2</sup>) minimum yield stress; 3.4 mm or 3.76 mm nominal wall thickness.
- ASTM A53, Grade B; 240 N/mm<sup>2</sup> (24 kg/mm<sup>2</sup>) minimum yield stress; 3.68 mm nominal wall thickness.
- BS 1139, Part 1, Section 1.1; 235 N/mm<sup>2</sup> (24 kg/mm<sup>2</sup>) minimum yield stress; 4.0 mm nominal wall thickness.
- EN 10219; 320 N/mm<sup>2</sup> (32 kg/mm<sup>2</sup>) minimum yield stress; 3.2 mm nominal wall thickness.



Figure 13: Stacked Scaffold Tubes

- All tubing produced shall meet the testing and inspection requirements of ASTM A500, including flattening test.
- Actual yield and tensile strengths shall be verified by Purchaser of scaffold tubing by:
  - receipt from Supplier and review of certified inspection test reports for each lot of tubing produced from the same heat of steel, and
  - by independent mechanical testing, per ASTM A370, of test specimens taken from two lengths of tubing for each lot of 500 lengths, or fraction thereof, received. All mechanical properties shall meet minimum requirements after galvanizing. All test reports shall be written in English.
- Each piece of scaffold tubing produced in accordance with the above specifications shall be clearly, continuously, and permanently marked to distinguish it from unacceptable, substandard tubing.
- All tubing shall be marked, prior to galvanizing, with the pipe manufacturer’s name or logo, applicable pipe fabrication specification (including Grade and nominal wall thickness), and year of manufacture continuously along its full length, in a position remote from any electric resistance weld (ERW) seam, using a low stress rolling die embossed marking system. The



marking interval shall not exceed 0.5 meter, with characters a minimum of 4 mm high and impression depth of at least 0.2 mm deep. Painted marking is unacceptable.

- Scaffold tubing conforming to other specifications may be used if approved by Vedanta, and if inspected and embossed as stated above.
- Steel tubing for tube and coupler scaffolds shall be hot-dip galvanized in accordance with ASTM A123. Steel tubing for system and fabricated tubular frame scaffolds may be painted.
- Scaffold couplers shall be marked as conforming to either BS 1139, EN74, or Vedanta approved equivalent specification. Couplers may be either pressed or of drop-forged type. All fittings (including couplers, clamps, joint pins, etc.) shall be galvanized or zinc coated to resist corrosion.

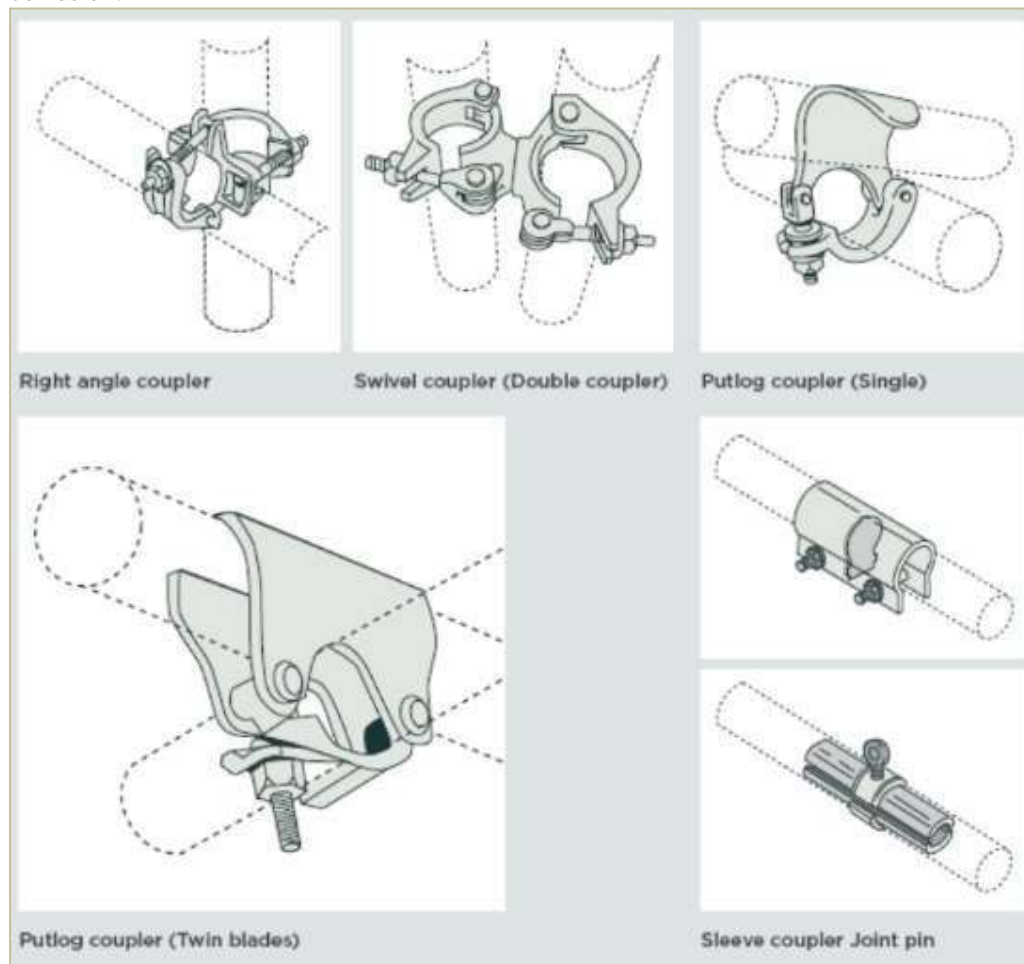

Figure 14: Types of Couplers

- Threaded parts of scaffold components and fittings shall be capable of attaining full thread engagement and shall be lubricated regularly.
- Always install scaffold components and fittings per manufacturer’s instructions.
- Girder couplers shall always be used in pairs.

- Individual couplers shall comply with the minimum safe working loads (SWL) in Table below. This shall be verified from the certificates/ records submitted by the manufacturer/ supplier.

Type Of Coupler	Type Of Load	Min. BS EN 74 Class	Minimum Safe Working Load (SWL) * (*BS 5973: 1993, Table 17)
Right-angle Coupler, also known as Double or Loadbearing Coupler	Slip along a tube	A	SWL = 6.25 kN (1400 lb.)
Adjustable Coupler, also known as Swivel Coupler		A	SWL = 5.3 kN (1190 lb.)
End-to-End Coupler, also known as Sleeve Coupler	Tension	B	SWL = 3 kN (675 lb.)
	Bending	B	SWL = 0.59 kN-m (435 lb. ft)
Bearer Coupler, also known as Putlog or Single Coupler	Force to pull the tube axially out of the coupler	-	SWL = 0.53 kN (120 lb.)
Girder Coupler (drop forged)	Shear	-	SWL = 30 kN per pair (6740 lb.)

- The components used to assemble scaffolds shall be inspected before each use and shall conform to requirements of this section regarding materials, strength, dimensions, etc.
- Scaffold components manufactured by different manufacturers shall not be intermixed unless the components are compatible (fit together without mechanical force) and the scaffold’s structural integrity is maintained. Scaffold components manufactured by different manufacturers shall not be modified in order to intermix them.
- Scaffold components shall be free from detrimental corrosion.
- Any scaffold component that is obviously damaged, excessively corroded, defective, or does not meet the applicable codes and standards shall be marked with bright fluorescent orange paint and immediately removed from site premises.
- Defective couplers shall be immediately destroyed and shall not be re-used on any Vedanta property or project site. However, if possible, defective sections of planks or tubing may be cut off. In this case, the plank or tubing may be reused.
- Scaffold components made of dissimilar metals shall not be used together because of the potential for galvanic corrosion.
- Scaffold components shall not be exposed to acids or other corrosive substances, unless adequate precautions have been taken to protect the scaffold from damage. □ Scaffold components shall be properly stored to prevent damage.

7.7 Basing Out a Scaffold

- Level the ground and clear the area on which the scaffold is to be erected of any debris.

- Determine how the scaffold will follow the perimeter of the building or structure and plan and measure carefully.
- Ensure the placement of the first standard is the high point of any slope.
- Ensure all standards and ledgers are plumb and level. If in doubt check with a spirit level. Maximum tolerance is + or - 5 degrees.
- Ensure all joints in standards and ledgers are in the correct position and made with the appropriate components.
- Do not use internal joint pins in ledgers as they are not rated for tension loads.
- Ensure all standards bear firmly against baseplates.
- Ensure all standards and ledgers are constructed with the appropriate span for the duty loadings of the scaffolding.
- Ensure the working platform is as close as practicable to the working face, with a gap of less than 300 mm.

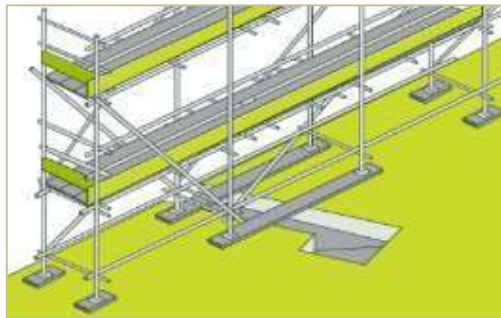

Figure 15: Basing out over a Trench

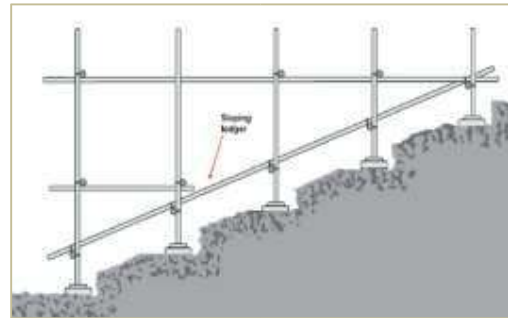

Figure 16: Basing out on a Slope

The following general safe work practices should be used when erecting a scaffold:

- Scaffold fittings and other connections should be securely tightened where required. Fittings should be in accordance with the manufacturer's or designer's specifications and the scaffolding plan. Use correct tools.
- Scaffolding including all bracing and ties, guy ropes or buttresses should be installed as the scaffold is erected.
- Consider using specifically designed loading platforms or back propping to prevent overloading the building floor or the scaffold.
- The bottom lift should have a maximum height of 3 m, and all other lifts should be between 1.8 and 2.1 m high.
- Work from a full deck of planks whenever possible.
- Harness, safety helmet and appropriate safety footwear must be worn at all times while erecting, altering or dismantling scaffolding. The harness must be hooked on to a suitable anchor point when there is a risk of a fall that could cause harm.
- The scaffold structure should be assembled with edge protection installed progressively (see Tunnelling method steps in Section 7.10) so no one is exposed to a fall. Scaffolders to maintain and work from within a "Scaffolder's Safe Zone" (see Section 10.2.2 and Annexure F for details) while erecting and dismantling scaffolds.

- Install signage/tags on the access points of incomplete scaffold stating 'INCOMPLETE SCAFFOLD' or 'UNSAFE SCAFFOLD' as soon as possible and where they are easy to see.
- The scaffold must be as close as practicable to and no more than 300 mm away from the working face. If this is not practicable, inside guard rails must be installed.
- Install all bracing, ties, guy ropes and buttresses as the scaffolding is being erected.
- Do not overload scaffold bays with scaffolding awaiting installation.
- When using a ladder to erect scaffolds, ensure the ladder is fixed to the scaffold structure to prevent movement and instability.
- Install ladders and stairs at the same time as scaffold platforms and edge protection.
- Non-proprietary platforms must have a minimum bay width of 675 mm wide.
- All platforms must allow 450 mm of clear access past stacked material and obstructions such as roof eaves.
- Inspect every part of the scaffold when it is complete to ensure it is safe and fit for purpose. Checklists in Annexure C can be used. When the scaffold is safe and ready for use, attach 'SAFE SCAFFOLD' signs at access and egress points.

### 7.8 Dismantling a Scaffold Safely

The following safe work practices should be used when dismantling a scaffold:

- Edge protection and a way to enter the scaffold can be removed as the scaffold is dismantled, provided it is removed at the last possible stage.
- A platform of at least 450 mm wide at the level the dismantling has reached should be in place, where possible.
- Ensure when dismantling the scaffold, the platform immediately below the level the worker is standing on has a full set of planks across its width and is no lower than 2 meters.
- A section of the scaffold may be left open, for example no platform in place, to allow the lowering of planks or other scaffolding components between levels.
- Scaffolding components should never be dropped in an uncontrolled way when dismantling the scaffold.

### 7.9 Altering a Scaffold

Control measures to eliminate or minimise health and safety risks (during scaffold alterations/modifications) include:

- Consulting the scaffold designer before making alterations,
- Scaffold alterations are in accordance with the scaffolding plan,
- Alterations do not compromise the structural integrity of the scaffold, and
- Systems are in place to identify unauthorised interference with the scaffold e.g. regular inspections.

### 7.10 Tunnelling Method:

This method not only protects the scaffolder but provides a safe zone for the completion of the lift and for others to use during alteration or dismantling. Tunnelling method should be used in all situations when it is not practicable to eliminate the risk of a fall. The steps involved are explained below:

	Tunnelling Method Steps	Notes
Step 1	Base out the scaffold and fully plank out the base lift (minimum 675 mm bay width) from below.	Staggered standards assist in installing the guardrail as this reduces the need to hemp all exterior standards.
Step 2	Install access stairs or ladders.	Ladders or stairs should be erected in the same sequence as the platform to allow safe access to the next lift.
Step 3	Connect lanyard to an appropriate anchor point and use the stairs or ladder to access the planked platform above.	The inside ledger is an appropriate anchor point for tube and coupler.
Step 4	While hooked on, install the first section of guardrail and stop end to create a safe zone above.	Equipment is passed up from below.
Step 5	<p>Progressively install the single guardrail on the scaffold.</p> <ul style="list-style-type: none"> <li>□ Install the next guardrail by staying within the safe zone and reaching down to connect the lanyard to the inside ledger at deck height in the next bay.</li> <li>□ Receive the standard in the safe zone, walk out and hemp the standard while attached to the inside ledger. This process can be repeated until the complete lift is a safe zone with a single guardrail on all exposed sides of the scaffold.</li> </ul>	<p>A scaffolder may only move along the scaffold for the maximum length of the longest ledger (typically the bay length or 6.5 m for tube and coupler scaffold).</p> <p>Once a single guardrail is installed the lift can be completed without hooking on the safety harness, unless there is a risk from a fall (e.g. from an unprotected platform, or if one needs to raise the planks they are standing on).</p>
Step 6	Repeat the procedures for subsequent lifts.	Single guardrails should be left in place on all non-working platforms (dummy lifts) to provide a safe zone for altering and dismantling the scaffold.
Step 7	The erection procedures above should be used in reverse when dismantling the scaffold.	<p>Planks should be flipped up on their edge prior to removal to protect the eyes of the scaffolder from debris left on the scaffold.</p> <p>This can be done from the deck level itself if one plank only at a time is lifted up onto its edge then replaced to maintain the planked deck.</p>

## 8. SCAFFOLD STABILITY

Any scaffold consisting merely of standards, ledgers and transoms or putlogs is not a rigid or stable structure. Scaffold stability may be achieved (or enhanced) by one or a combination of the following methods:

- Tying the scaffold to a supporting structure,
- Guying to a supporting structure,
- Increasing the dead load by securely attaching counterweights near the base, and  Adding bays to increase the base dimension.

### 8.1 Bracing and Tying

Every scaffold shall be effectively braced to make it rigid and tied or guyed to make it stable.

Single pole scaffolds shall be braced longitudinally and the double pole scaffolds shall be braced both longitudinally and transversely so that the scaffolds form a rigid and stable structure.

Longitudinal bracing - The longitudinal bracing shall be provided on the outer face of the scaffolding by means of:

- a diagonal face bracing in the end bays and one or more diagonal face braces (or facade braces) between the end bays pitched at an angle to form a diagonal across the bays; or
- zig zag face bracing in the end bays and also in intermediate bays, or
- any other equally effective method approved by site in-charge. See Annexure A for detailed illustrations on bracing.

Distance between braced bays - The maximum distance between braced bays in

IMPORTANT: Braces shall be attached to any lift of scaffold shall not exceed 10 m.

standards and as closely as possible near the junction with ledgers (node points) and

Length of brace - The brace member shall scaffold. be continuous (that is, without any break) the direction of the brace.

shall extend from base to the top of except when it is necessary to change

Transverse bracing - In case of double pole scaffolds, in addition to face or zig-zag bracings required as above, transverse bracing or 'heel' and 'toe' braces shall also be provided at each end of the scaffold. If the length of the scaffold exceeds 15 metres, it shall be provided in addition at 'intervals not exceeding 15 metres apart.

Heel and Toe Bracing - Where it is impracticable to provide ties at vertical spacing specified, heel and toe bracing shall be provided between tie points. Even with such heel and toe bracings the distance between ties shall not exceed 15 m.



## Guidance Note – Scaffolding Safety

Plan Bracing - Where it is impracticable to fit ties at horizontal spacing specified plan bracings shall be provided between possible tie points as shown in Fig. 11. Even with such plan bracing, the distance between ties shall not exceed 15 m.

**IMPORTANT:** When plan or heel and toe bracings are provided, the ties shall be capable of carrying extra loads which will be imposed on them.

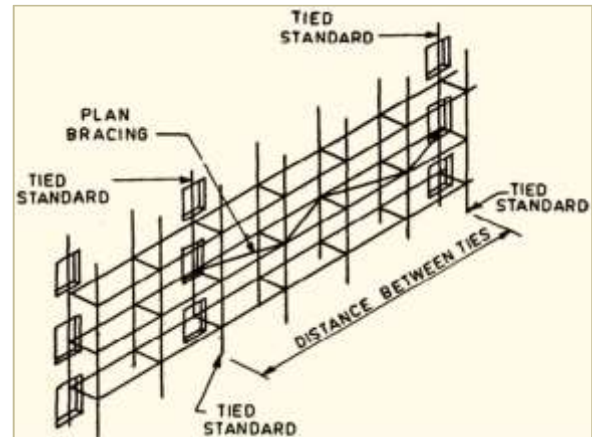

Figure 17: Plan Bracing

Additional bracing - Where, due to difficulty in attaching ties to the building or structures, the tie spacing specified above cannot be complied with, additional bracing shall be provided in the scaffold between ties points as specified below.

Where gale force winds are expected, it may be necessary to provide additional ties, guys or other suitable supports as decided by the engineer-in-charge.

### 8.2 Rakers or Outriggers

These are tubes attached to a scaffold to increase its base width, helping to stabilise it.

- Raking tubes must be braced to prevent bending and spreading.
- Do not attach the raking tube more than 300 mm from the standard.
- The distance between braces (node points) on a raker must not exceed 3 m.
- Where possible the horizontal brace should be above head height.
- For tube and fitting scaffolding, attach the tube brace to the standards of the scaffold or to ledgers or guardrails that are connected with right angle couplers.

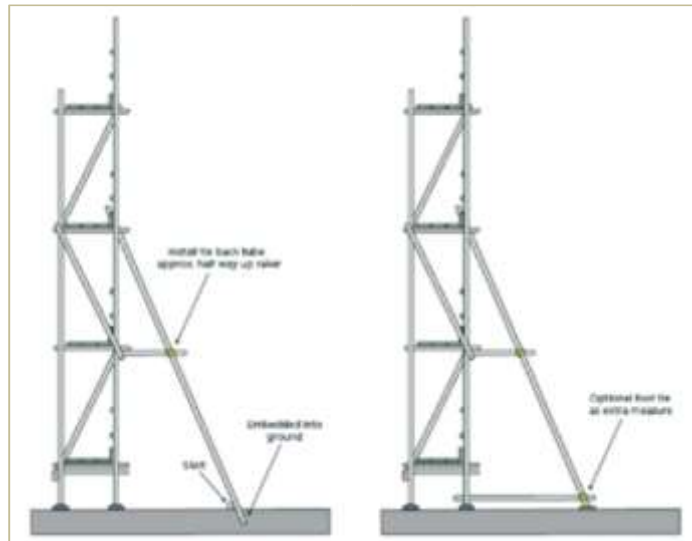

Figure 18: Raker/Outrigger Embedded in Ground (Left) and at Ground Level (Right)

### 8.3 Tying and Anchoring

The stability of a scaffold structure is dependent, among other things, on the security of the anchors used to tie it back. It is of utmost importance that the anchors and ties are correctly selected and installed and, where necessary, tested.

Anchors and ties are critical to the stability of the scaffold, preventing it from falling towards or away from the structure, and stabilising individual standards to prevent them from buckling. Ties should be connected to the scaffold with right angle couplers and be connected to both the inside and outside standards. Ties through window openings, etc., shall be fixed at sill level. Ties shall be fixed either to both standards or to both ledgers as close as possible to the standard/ledger junction. Typical tying systems are shown below.



Figure 19: Tying the Scaffold to the Wall using a drilled in anchor

Similarly, every single pole and double pole scaffold shall be effectively tied to a building or adjacent structure to prevent movement of the scaffold either towards or away from the building or structure. When the height of the scaffold is less than 03 times the width of the base, alternatively, the scaffold may be supported with outriggers/ rakers or buttressed.

As the inside standards of double pole scaffolds are not normally braced longitudinally by a face brace or zig-zag brace, the ties shall be sufficiently rigid to prevent any longitudinal movement as well as in the scaffold structure.



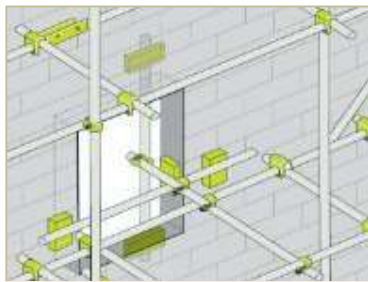

Figure20: Lip/OpeningTie

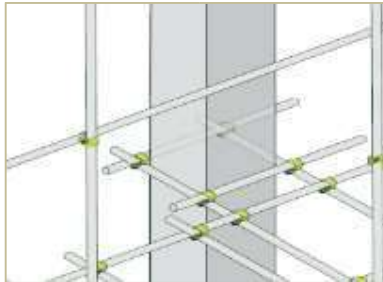

Figure21: Box-Tie



Figure24: ARigidTie

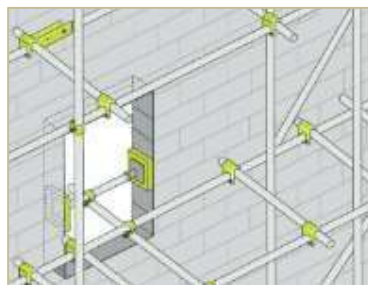

Figure25: Reveal-Tie

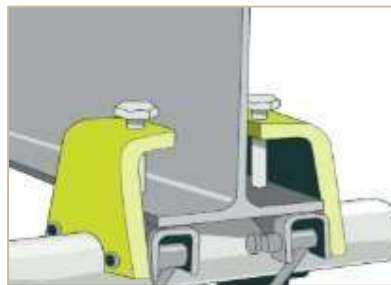

Figure26: BeamClamps

Aspects which need to be considered in selecting anchors for tying scaffold structures are:

- The type of linkage to the scaffold structure
- The base material and suitability of the structure
- Working load compared to recommended or allowable load
- The way loads are transferred through the ties and the direction they are applied – tension, shear, bending or a combination.
- The need for testing; and
- The potential for corrosion.

Most common types of tie-methods using embedded anchors are shown below:

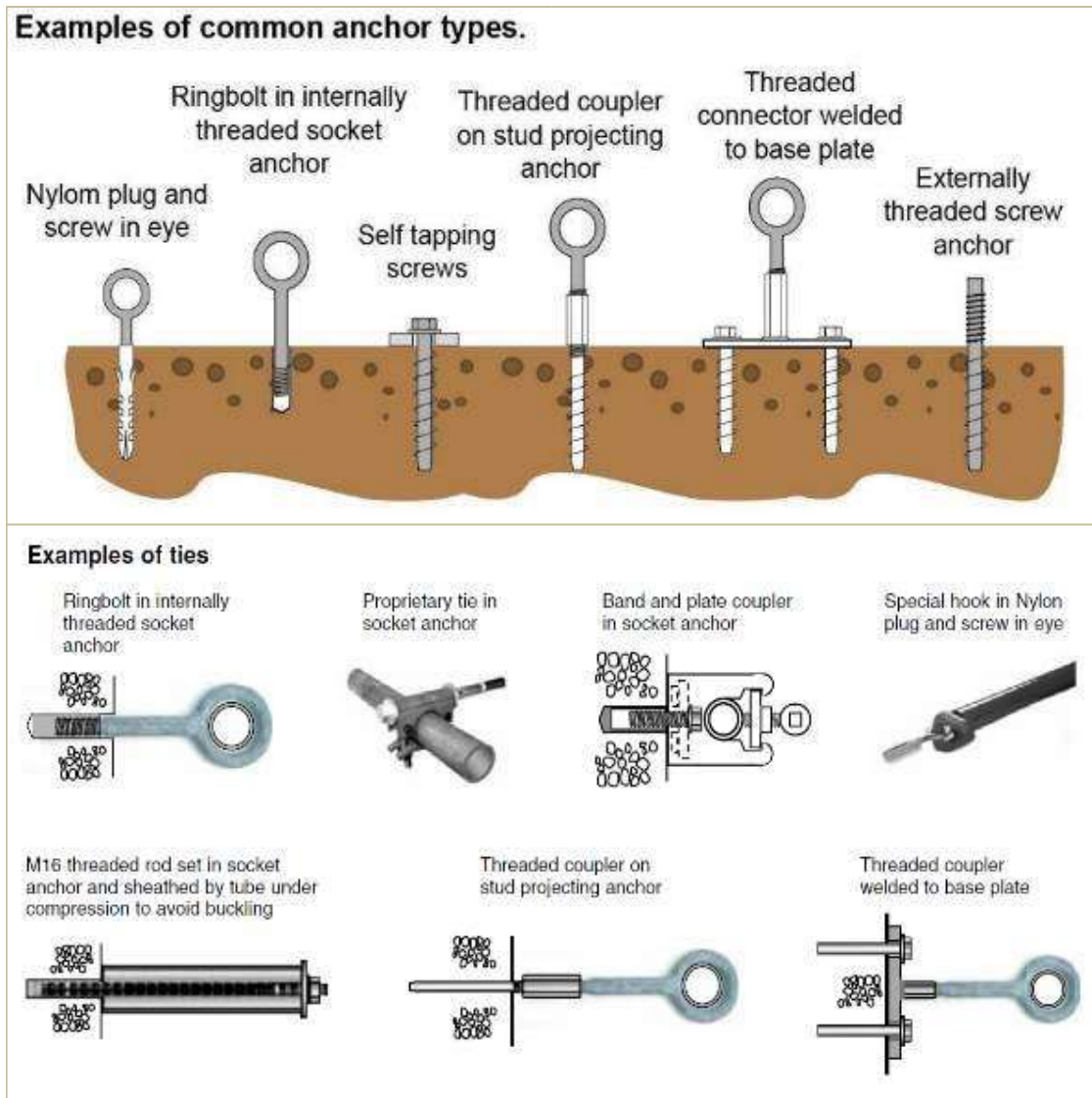

Figure 27: Common Types of Embedded Anchors and Tie Methods

For specific scaffolding, suitable tie methods and spacing should be determined in accordance with the instructions of the manufacturer, designer or supplier. Control measures for tying scaffold include:

- Consult with the scaffold designer, manufacturer, supplier or an engineer if it is not practical to position the ties in accordance with the instructions.
- A competent person/ scaffold supervisor should regularly inspect the existence and effectiveness of scaffold ties to ensure they are not modified or altered by users/ unauthorised people (e.g. finishing trades such as painters, bricklayers etc. who may loosen, relocate or remove ties to gain access to walls and openings).
- Use additional ties if:

## Guidance Note – Scaffolding Safety

- The scaffold is sheeted or netted due to increased wind loadings, □ It is used as a loading platform for materials or equipment, and □ Lifting appliances or rubbish chutes are attached.
- Attach extra loads on the scaffold (e.g. signs and perimeter containment screens) only after consulting with the scaffold design engineer or the supplier.
- Cast-in anchors or ‘through bolts’ that pass through a wall are preferred to drill-in expansion or chemical anchors for securing scaffold ties, as they can possibly due to faulty tensioning.
- Deformation-controlled anchors including self-drilling anchors and drop-in (setting) impact anchors are not recommended.
- Drill-in expansion anchors should be limited to the load (torque) controlled type. The working load limit (WLL) should be limited to 65 percent of the ‘first slip load’ stated in the information provided by the supplier.
- Where chemical anchors are used, all anchors should be tested and proof loaded to the working load multiplied by



Figure29: AnAnchorTesting Devicehelpsinensuring whethertheinstalledanchors areadequateornot

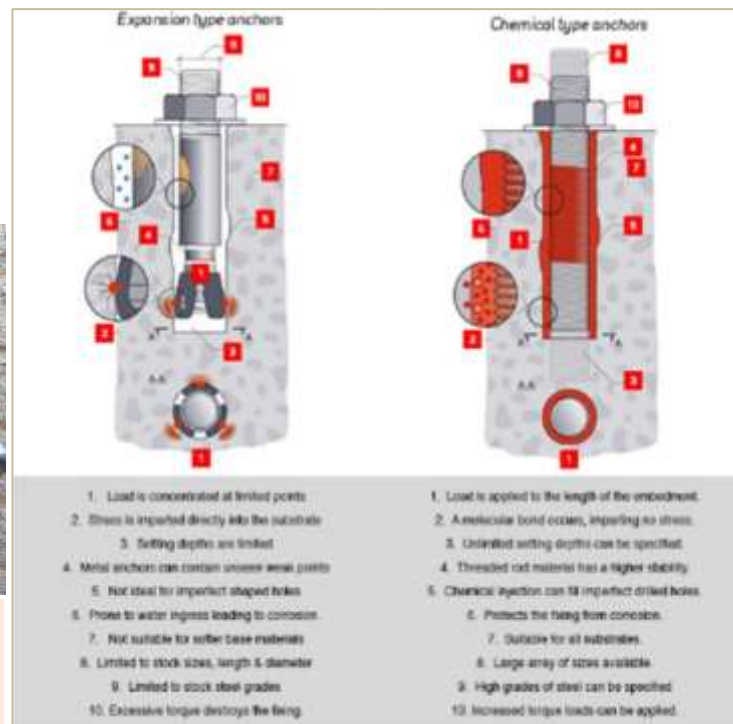

Figure28: ComparisonofExpansionTypeev/sChemicalAnchors

a factor of 1.25.

- Drill-in expansion anchors should be installed using a torque wrench set to the required torque, unless the anchor has an in-built torque indicator. Documented verification should be kept on site, stating:
  - The anchor setting torque,
  - Install date, and
  - Location and name of the competent person installing the anchors.

- Drill-in expansion or chemical anchors should have a safety factor of 3 to 1 on their failure load. If any anchors fail the remaining anchors on the same level should be tested.
- Ties should not obstruct access along the working and access platforms.
- Ties should interconnect with both the inner and outer scaffold standards unless otherwise specified by an engineer to increase the rigidity of the scaffold.
- Ties from scaffold to structure should be designed to be non-pivoting and fully secured to ensure they cannot be loosened.

Tie- spacing:

The vertical spacing of ties shall not exceed 4 m. Longitudinally, ties shall be fixed at each end of the scaffold and at intervals along the length not exceeding the spacing as set out in Table below.

Height of Scaffold	Horizontal Spacing of Ties			Vertical Spacing
	Between GL and 6m	Between 6m and 12 m	Between 12m and 18m	
Up to 6m	Every 5 <sup>th</sup> Standard or 10m	-	-	4m
Up to 12m	Every 4 <sup>th</sup> Standard or 8m	Every 5 <sup>th</sup> Standard or 10m	-	4m
Up to 18m	Every 3 <sup>rd</sup> standard or 6m	Every 4 <sup>th</sup> Standard or 8m	Every 5 <sup>th</sup> Standard or 10m	4m

Note: Before removing any tie to fix window frames etc. another tie should be fixed so that the tie spacing specified above does not exceed or alternatively plan bracing or heel and toe bracings shall be provided.

## Guidance Note – Scaffolding Safety

### 9. SCAFFOLD WORK PLATFORMS AND ACCESSORIES

#### 9.1 Scaffold Work Platforms

- Each scaffold should be designed to carry the required number of working platforms and to support its live loads.
- Scaffold planks/ boards on working platforms should:
  - Have a slip-resistant surface,
  - Not be cracked or split,
  - Be of uniform thickness,
  - Be secure, so it cannot be kicked off or susceptible to uplift or displacement during normal use,
  - Be positioned so no single gap between planks exceeds 10 mm, and
  - Not be lapped on straight runs of modular and tube and coupler scaffolding, but may be lapped on hanging bracket scaffolds where butting of planks at a pair of brackets cannot be achieved.
- Metal planks lapped should be secured using fixings, for example metal strapping. Tie wire or another system that is not structurally rated should not be used to secure planks on hop-up brackets.
- Each hop-up bracket should be provided with tie bars unless constructed with scaffold planks locked into position to stop brackets from spreading apart or causing planks to dislodge, unless otherwise specified by the scaffold designer.
- The overhang of planks which are supported by putlogs should be greater than 150 mm but less than 250 mm—otherwise uplift might occur.
- Working platforms should have “duty classifications” and dimensions complying with the manufacturers’ information on loadings. Recommended duty ratings for scaffolds are given below:

- Light Duty – up to 225 kg per platform per bay. Examples include painting, electrical work, many carpentry tasks and other light tasks. Platforms should be at least two traditional scaffold planks wide (approximately 450 mm).
  - Medium Duty – up to 450 kg per platform per bay. Examples include general trades work like tiling and light steel framing. Platforms should be at least four traditional scaffold planks wide (approximately 900 mm).
  - Heavy Duty – up to 675 kg per platform per bay. This is what is needed for concrete block laying, bricklaying, concreting, demolition work and most other work tasks involving heavy loads or heavy impact forces. Platforms should be at least 900 mm wide.  Special Duty – has a designated allowable load as designed.
- A scaffold platform board/plank shall not project beyond its end supports to a distance exceeding four times the thickness of the plank unless it is effectively secured to prevent tipping. Cantilever of scaffold planks shall be avoided. Ledgers or putlog should be erected to support the ends of such planks.



## Guidance Note – Scaffolding Safety

- Boards used for the platforms, gangways and runs shall be of uniform thickness closely laid, and, securely fastened in place.
- Planks shall be inspected for defects, including damage, decay and warping, prior to each use.
- Planks shall not be painted, treated, or coated in any way (except at the ends) that could conceal defects or obscure the top or bottom surfaces.
- Planks shall be properly stacked, off the ground, on a suitable foundation.
- Scaffold planks shall not be used as concrete forms, trench shoring, or as sills for scaffolds.

### 9.2 Manual Handling Aids

Manual handling aids can greatly increase the efficiency of operations and reduce the risk of fatigue and manual handling injuries.

**Hand lines:** Where a small amount of material is to be hoisted, a rope or hand line can be used. The minimum rope diameter is 12 mm.

**Gin Wheel and Rope:** Safe method for raising and lowering material when working at height. However, its use is laborious as only limited material can be handled at any one time.

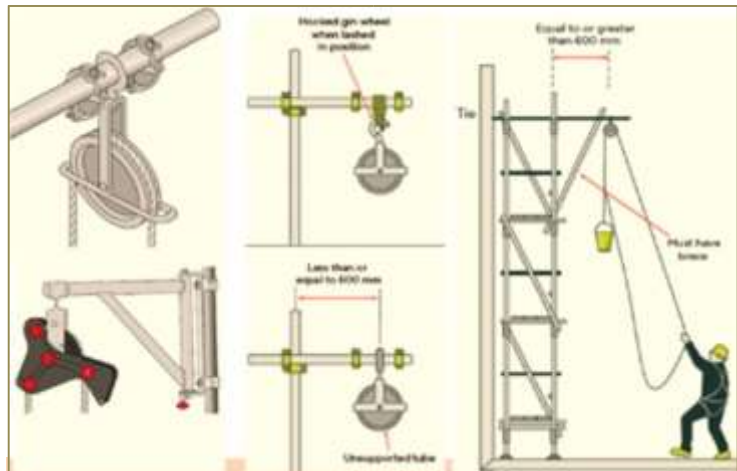

Figure30: GinWheels-VarietyTypes

### Loading Bays

Loading bays (also known as towers) can be constructed as standalone structures or attached to access scaffolds for the loading and storage of materials and equipment.

A key feature for loading bay platforms, and good practice, is to use a loading bay gate system that allows the passage of bulk goods using mechanical handling equipment (e.g. forklift truck) whilst maintaining collective fall protection.

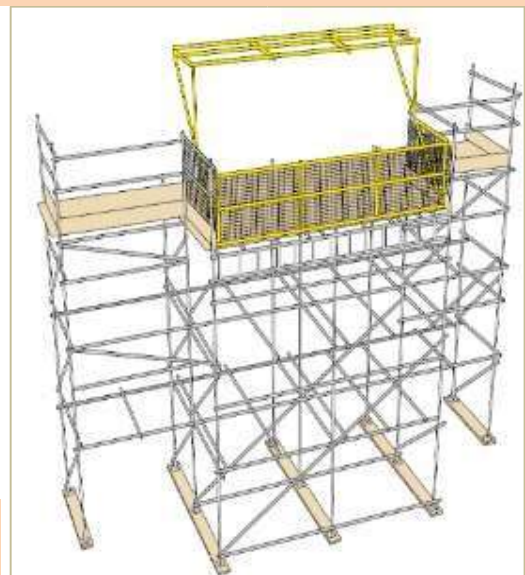

Figure31: ExampleofLoadingBay(closed)

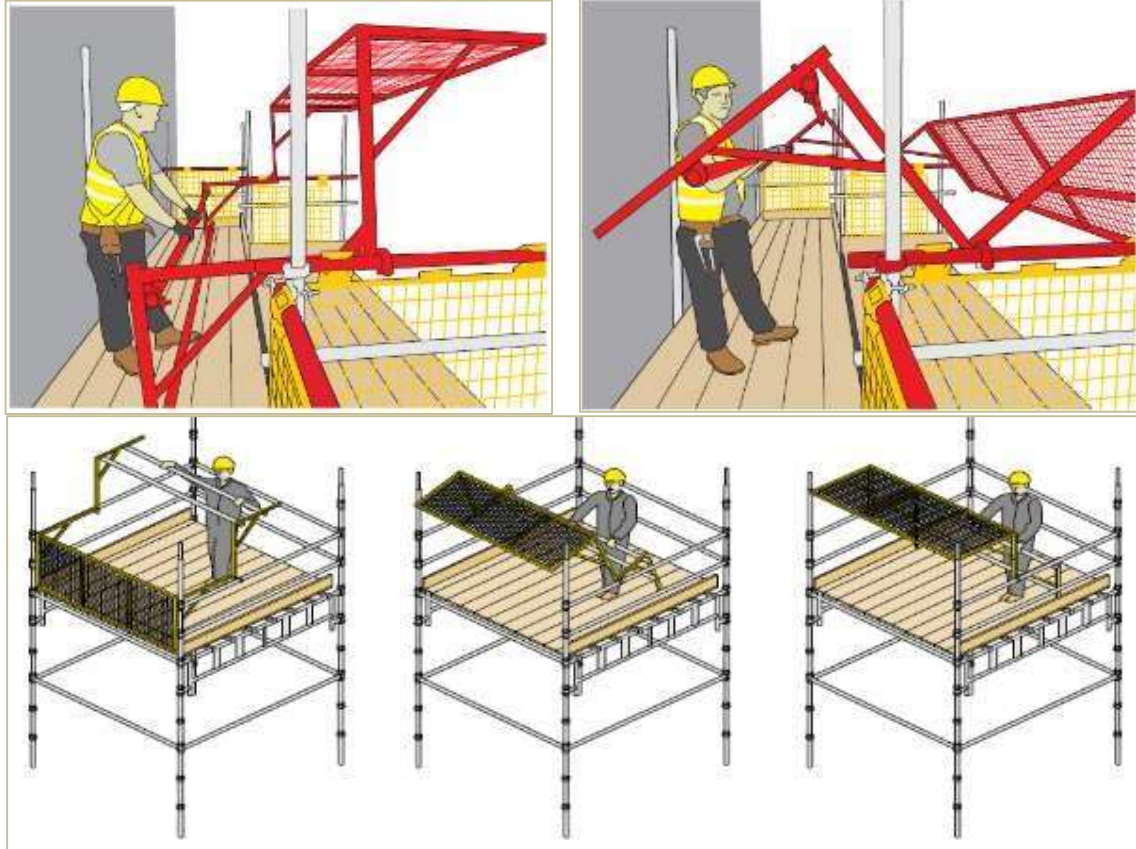

Figure 32: Example of Loading Bay Gate System



## 10. KEY HAZARDS AND COUNTERMEASURES

### 10.1 Fall of Materials and Personnel

- Control measures to eliminate or minimise the risk of a falling object can include fall arrest platforms, catch platforms, overhead protective structures, perimeter screening, and exclusion zones. Chin straps for hard hats and tool lanyards can be used by scaffolders to minimise the risk of equipment falling.
- To protect workers on lower platform against falling objects from higher levels, overhead protection should be provided on the scaffold.
- This protection should be not more than 3 m above the platform/floor and should be planking or other suitable material.
- Where persons are required to work or pass underneath (for example, building entrances or pathways,) a scaffold upon which men are working, a screen or canopy shall be provided for their protection from falling objects. Such screen should extend to a distance at least one metre beyond the edge of the scaffold above the passage to catch any material which may fall. For ordinary conditions a net with a mesh size of 25 mm is satisfactory (see Figure 33).
- Supervisory staff, inspecting officials or such persons who have to go to the vicinity of the scaffolding should wear safety helmets (see IS: 2925 - 1984\*) within a zone of at least 10 m to be protected from falling objects escaping such screen or canopy.
- Hazards which may increase the risk of a fall while erecting, altering or dismantling a scaffold include:
  - Poor environmental conditions, such as:
    - o Strong winds that may cause workers to lose balance
    - o Rain causing slippery work surfaces, and
    - o Glare emitted from work surfaces or poor lighting affecting visibility.
  - Materials, equipment or protruding objects below, or in adjoining work areas e.g.:
    - o Pallets of construction materials,
    - o Vertical reinforcing steel,
    - o A rubbish skip,
    - o Exposed starter bars
  - Void areas not identified or protected e.g. ladder access voids
  - Incomplete scaffolds or loose scaffolding components where work is being done, or is likely to be done, and
  - Inadequate training, instruction and supervision of scaffold workers.

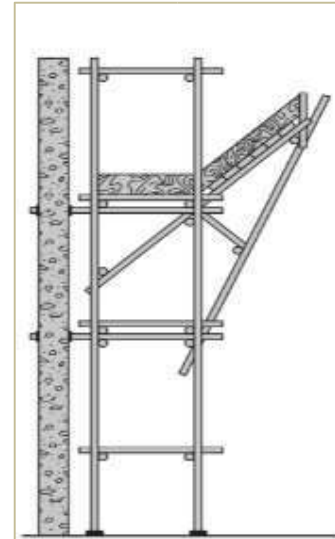

Figure33: Catchplatform/  
fan

#### 10.1.1 Edge Protection

Edge protection may be used as a risk control measure to prevent the risk of death or injury from a fall during work at height. Guardrails should be considered as an essential part of every scaffold and should be provided for all working platforms higher than 2 m above the floor level. Edge protection should include controls for falling objects, for example toeboards.

## Guardrails

Standard railings may be constructed, of pipe or any other metal sections. The railings shall consist of a top rail from 900 to 1050 mm above the platform level and intermediate rail halfway between the top rail and the platform. The railings should be mounted on standards or uprights.

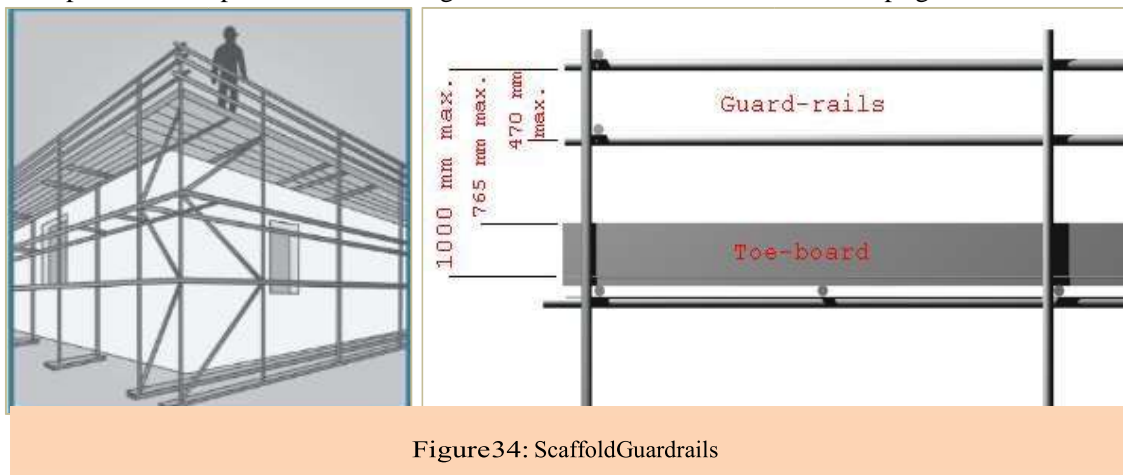

Figure 34: Scaffold Guardrails

- Guardrail systems (consisting of top rails, midrails, toe boards, and support uprights) shall be installed on all open sides and ends of all elevated work areas (including scaffold platforms and stair landings) where a person could fall 1.8 meters (6 feet) or more.
- The top edge height of top rails shall not be less than 0.95 meter (38 inches) and not more than 1.15 meters (45 inches) above the walking/working surface of a platform.
- Mid-rails shall be installed approximately halfway between the walking/working surface and the top rail.
- Top rails and midrails shall be securely fixed to the inside of vertical uprights (i.e., posts). Vertical uprights supporting guardrails shall not be spaced more than 2.7 meters (9 feet) apart.
- Guardrail systems shall be able to withstand, without failure, a force of at least 90 kilograms (200 pounds) applied in any downward or horizontal direction at any point on the top rail or equivalent member.
- Guardrail systems shall be installed before an elevated work area may be used by anyone other than the scaffold craftsmen (scaffolder).
- The ends of all horizontal guardrails shall not overhang the end uprights except when such overhang does not constitute a projection hazard to workers.
- Whenever the horizontal distance from the edge of an elevated work area (including scaffold platforms) to the face of the wall or structure exceeds 360 mm (14 inches), a guardrail system shall be erected along the edge or personal fall arrest systems shall be used.

- At hoisting areas, a guardrail system at least 1.2 meters (4 feet) long shall be erected (if possible) on each side of the access point through which material is hoisted. A chain or gate shall be properly secured across the opening between the guardrail sections when hoisting operations are not taking place.

### 10.1.2 Falling Material Protection

#### Toe-boards

The platform edges of every scaffold shall be equipped with toe boards to eliminate hazard of tools or other objects falling from the platform. Toe-board shall be so placed that no opening remains between the flooring and the toe-board. Toe-boards shall be installed along all edges of elevated work areas (including scaffold platforms) more than 1.8 meters (6 feet) above lower levels, unless personnel access to the lower level under the elevated work area is physically prevented.

Toe-boards shall conform to the following requirements:

- The vertical distance from the top edge of the toe board to the level of the walking/ working surface shall be at least 100 mm (4 inches).
- Toe-boards shall be at least 25 mm (1 inch) thick.
- Toe-boards shall be securely fastened in place along the outermost edge(s) of the platform and have not more than 6 mm (1/4-inch) clearance above the walking/ working surface.
- Toe-boards shall be solid and capable of withstanding, without failure, a force of at least 23 kilograms (50 pounds) in any downward or horizontal direction at any point along the toe-board.

#### Catch Platforms

A catch platform can be used as a risk control measure to minimise the distance a person could fall during work at height and to catch falling objects (see Figure 4).

#### Brick-Guards

The purpose of a brick guard is to prevent materials from falling off the working platforms of scaffolds where toe-boards do not offer sufficient protection. Brick-guards should be robust enough to prevent material falling from the scaffold.

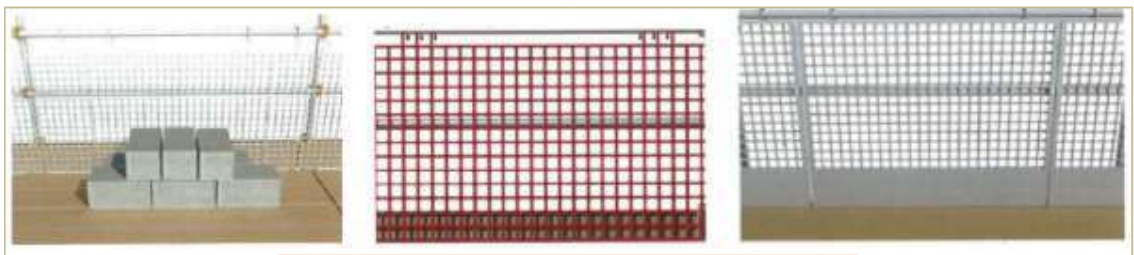

Figure35: ExamplesofvarioustypesofBrick-guards

With brick-guards, there is a range of different types of mesh size available to suit all situations. Specific advice cannot be given as to the type of brick-guard required (as this should be subject to a specific on-site risk assessment), but the following gives good general advice. There are generally three types of brick-guard on the market (made of various materials, including metal and plastic):

- Brick-guards with fixed handles (designed to hook over the top guardrail);
- Brick-guards with detachable handles.
- Brick-guards with no handles (secured to top guardrail with suitable tying methods).

### Perimeter Containment Screening

Where tools, materials, or equipment are piled to a point higher than the top edge of the toe-board and where there is the danger of objects falling through guardrails and striking workers or equipment below, a protective screen consisting of a minimum No. 18 gauge wire with a maximum 13 mm (½-inch) mesh, shall be securely fixed to the toe-board, midrail, and toprail.

Where scaffolds are erected over footpaths or other areas over which persons work or pass under protection against hazard of falling objects is necessary. Under these conditions, it is necessary to enclose the space between the toe board and the top railing. The material used for enclosing the space will depend upon the working conditions. On scaffolds used for cleaning surfaces of buildings with chemicals or other corrosive agents, a suitable protective covering such as tarpaulin or PVC sheets, be used to protect persons working or passing near the scaffold from spillage of such liquids.

- Screens may be made of mesh, a high quality shade cloth, timber, plywood, metal sheeting or other material suitable for the purpose.
- Before using perimeter containment screening, consideration should be given to other risks like conductivity of electricity and loads.
- Perimeter containment screens should be located inside the standards on working platforms or in accordance with the manufacturer's specifications. Where used, the lining should be attached to the inside of the mesh.
- The lining can be attached using non-structural locating product which keeps the lining in place while minimizing damage to the lining. However, the extra wind loading represented by using linings should be considered when selecting a lining material.
- Perimeter containment screens can act as a 'sail area' leading to increased wind loads on the scaffold. The framework supporting a screen should be able to support loads resulting from the screen.



Figure 36: Examples of cloth type and metallic mesh type Perimeter Containment Screens

## Guidance Note – Scaffolding Safety

- The scaffold design and its ties fitted with containment sheeting should be approved by a competent person, for example an engineer with experience in structural design.

### 10.2 Fall Protection in Scaffolding Works

The major life-threatening hazard involved in scaffolding is the risk of falls from a height, falling scaffold components and contact with overhead electric lines.

**IMPORTANT:** Scaffolders are not falling, either by the provision and use of permitted to work at height while exposed to a risk of a fall, working platforms and guardrails or, where without taking appropriate actions to this prevent or protect against a fall from height.

Persons at work to be protected from the danger of collective safeguards such as adequate being safety nets or personal protective equipment such as suitable fall arrest systems (incorporating safety harnesses, lanyards and anchorages). Employers must provide fall protection for each employee on a scaffold more than 10 feet (3.1 meters) above a lower level.

Persons at work to be protected from the danger of collective safeguards such as adequate being safety nets or personal protective equipment such as suitable fall arrest systems (incorporating safety harnesses, lanyards and anchorages). Employers must provide fall protection for each employee on a scaffold more than 10 feet (3.1 meters) above a lower level.

#### 10.2.1 Fall Prevention for Scaffolders

The key priority and objective for scaffolders is to establish collective protection by creating a scaffolders' safe zone and therefore minimising the time exposed to a fall risk and reliance upon personal fall protection equipment (safety harnesses).

- At all stages in the Working at Height risk control hierarchy, scaffolders must consider collective protection over personal protection. This means using measures that protect everyone working at height at all times when in place, such as guardrails or safety nets before specifying personal fall arrest equipment that is reliant on being attached.
- Collective safeguards such as, the use of ladders or stairs and the placing of decking and guard-rails on each platform before scaffolders go onto it or else as soon as practicable.
- Where scaffolders will be working on a standard-width scaffold for only a very short time, they may work off a three board- wide platform provided that guard-rails are installed immediately following the these collective methods of working will installation of the boards. not completely remove the risk of a fall
- Where the necessary collective safeguards in all situations, therefore recognized will be inadequate during certain phases of that scaffolders will still be required to the work, personal protective equipment, wear and use personal fall protection (e.g. nets, fall arrest systems,) should be equipment when working at height. used to supplement the collective safeguards.

**IMPORTANT:** The introduction of these collective methods of working will installation of

Scaffolders should consider measures that create a safe zone (see Section 10.2.1 The scaffolders' safe zone) by preventing falls from height, such as providing adequate work platforms with suitable



guardrails or other collective measures, before resorting to personal fall protection equipment (i.e. harnesses).

### 10.2.1 Scaffolders Safe Zone

This section identifies what a scaffolders' safe zone is, and how to safely create it.

Scaffolders must focus upon creating a scaffolders' safe zone utilizing one, or a combination of the methods detailed in this section, as a priority when working at height, with a minimum of:

- a correctly boarded and supported platform without gaps through which someone could fall (see Section 9.1); and,
- a single main guardrail (950mm above the platform) where there is a risk of a fall.

Scaffolders should focus on establishing a scaffolders' safe zone as their priority when working at height, where appropriate, to reduce reliance on Personal Fall Arrest Equipment (PFAE).

It must be recognised that the scaffolders' safe zone does not completely eliminate the risk of a fall for all scaffolding operations, for example when raising or lowering working platform boards as the erection or dismantling of the scaffold progresses. Personal fall protection equipment (safety harnesses) will still be required at some point in the system of work unless every lift remains fully boarded and all edges are protected with guardrails or similar.

When scaffolders are working without a fully boarded platform (e.g. raising or lowering platform boards) or without guardrail protection, then they must remain continually clipped on to a suitable anchor point when exposed to the risk of a fall. When scaffolders encroach from a scaffolders' safe zone to within 1 metre of an area not protected by guardrails they are considered 'at risk' and personal fall protection equipment must be used (Figure 9).

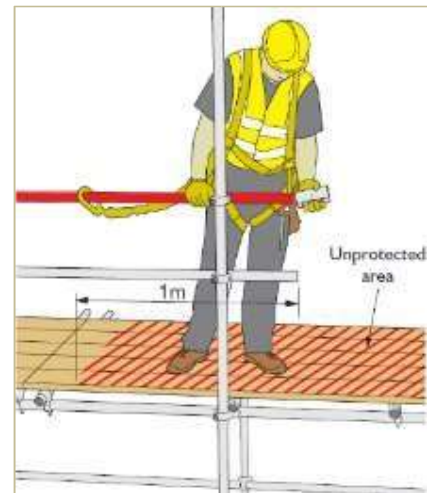

Figure 37: Scaffolder working without a fully-boarded platform

### Working Platforms

It is important to identify that there are different types of working platforms used in scaffolding.

The term "working platform: applies to a temporary platform provided for access at various stages of the erection, use, alteration and dismantling of scaffolding, these include:

- The finished working platform (Used by others)
- Other purposes (e.g. loading towers for materials that require personnel access)
- Erection, alteration or dismantling of scaffolding ONLY! (The scaffolder's safe zone)

Scaffolders must consider the following working platform requirements for creating the scaffolders' safe zone:

Figure 38: (1) A temporary working platform to form scaffolders' safe zone; (2) A finished work platform for users of scaffold

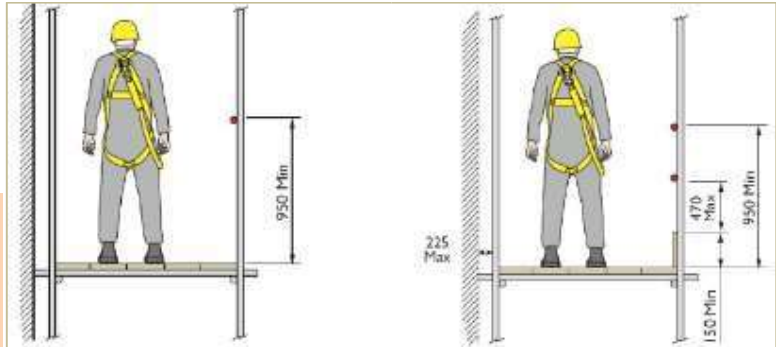

- Scaffolders should install a minimum of a single guardrail, at least 950mm above the platform, on each face of the scaffold where a fall could occur. On finished working platforms for others, progressively install the double guardrails (with no gap greater than 470mm).
- Inside gaps (greater than 225mm) between the inner standard of the working platform and façade/structure or openings in the façade (e.g. windows), where scaffolders face a risk of falling, need to be protected with guardrails in same manner as the outer faces of the platform.
- Guardrails should be erected and left in place for the duration of the works (e.g. for alterations or dismantling).
- Scaffolders' guardrails should be installed on all lifts where the lift height is greater than 950mm (e.g. progressive bricklayers' lifts 1.35-1.5 metres).
- When it is necessary to reach below a single guardrail scaffolders must be clipped on to the highest available anchor point (e.g. when fixing bracing or handling materials below the height of the single guardrail see Figure 39).
- When raising or lowering materials scaffolders should be clipped-on or create a safe handling platform with double guardrails, including stop-ends so that there is no gap greater than 470mm through which a scaffolder could fall (Figure 40).
- When moving, raising or lowering platform boards, working less than 1 metre from an exposed edge or outside of guardrail fall protection, where exposed to a risk of a fall, scaffolders must be clipped on.

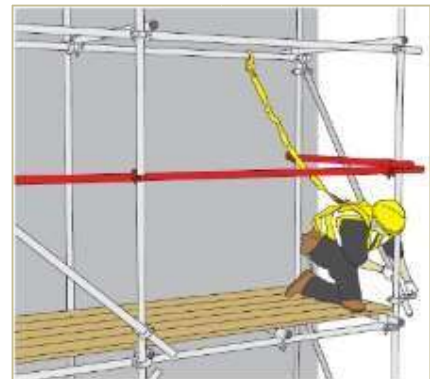

Figure 39: A scaffolder reaching below the single guardrail must be tied-off



Figure 40: Safe handling bay (with double guardrails, stop ends returns) - used for raising and lowering materials.



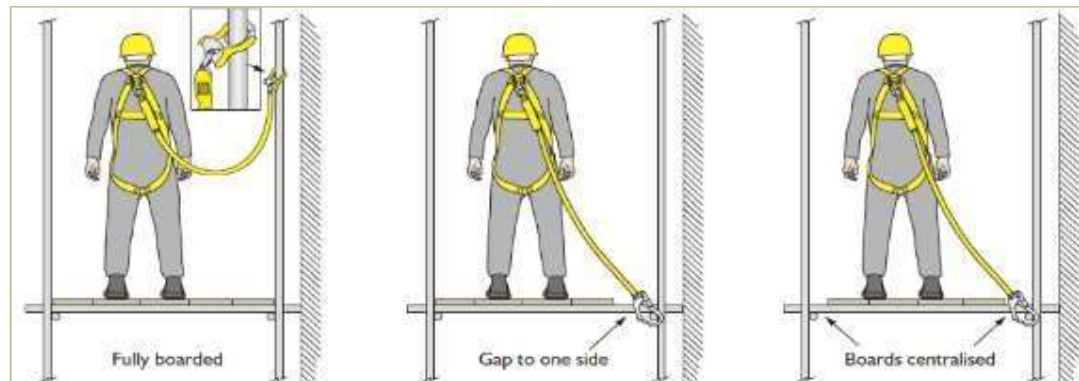

Figure 41: A fully boarded platform, with a maximum gap of 225mm may be allowed if the tie-off point (ledger) is below the decking.

- The working platform should be fully boarded out, without gaps through which a person could fall, except when access is required to a ledger below the lift for attaching fall arrest equipment, then one board may be omitted for ease of access to the ledger as an anchor point (see Figure 41).
- Scaffold boards must be correctly supported by transoms or bearers [e.g. 38mm thickness timber scaffold boards for scaffold load classes 1 to 3 must be supported every 1.2 metres]. Exceeding the specified maximum span of scaffold boards increases the risk of a fall due to the board failing.
- Ensure boards are suitably stable and trap-ends avoided by not exceeding appropriate overhangs [e.g. 38mm thick timber scaffold boards (BS 2482) have a minimum overhang of 50mm and a maximum overhang of 150mm.]
- In the case of proprietary system scaffolding battens and decking, these must be used in accordance with supplier's instructions. Particular consideration must be given to the method of raising and lowering battens or decks for system scaffolding and the protective measures recommended by the manufacturer.
- Gaps formed in working platforms to create ladder access traps should be protected against accidental falls once the scaffold is completed. Scaffolders should install these measures progressively to provide protection for themselves as the job progresses.

- The first lift should, where possible, be boarded out from below to avoid the risk of a fall when working at low level (Figure 15).
- All other lifts, where practical, should be boarded out and removed from below.
- All guardrails should be secured so that they cannot become accidentally displaced should someone fall against them.
- Lateral gaps in guardrails are only permitted at a point of access to a ladder or stairway where a gap is necessary.
- Where the fall risk to the interior of the building from the external scaffolding exists, scaffolders and others should be protected with a collective fall arrest system, rather than guardrails or internal scaffold platforms (see Figure 43).

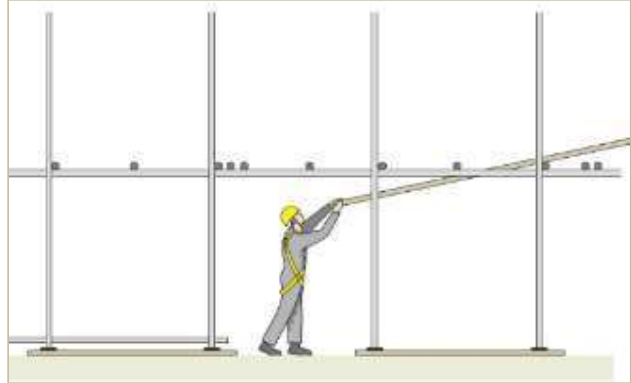

Figure42: Boardingoutthefirstliftfrombelow

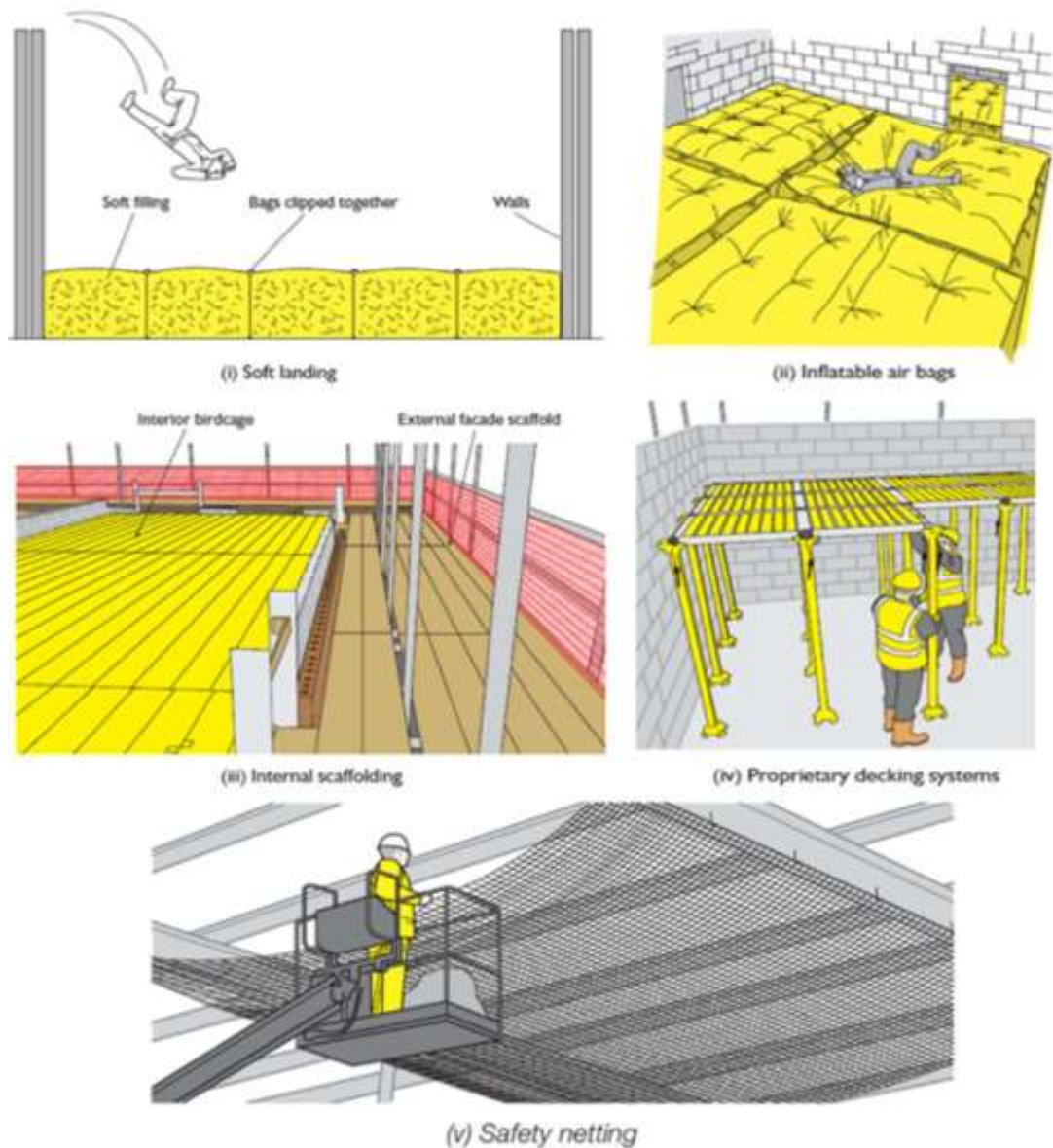

Figure 43: Examples of other collective fall arrest systems to provide internal fall protection

### 10.2.2 Personnel Fall Arrest Systems

It is widely acknowledged that there is an inherent risk of a fall in all scaffolding operations, which cannot be completely eliminated. The use of fall arrest equipment does not prevent a fall occurring and does not eliminate the risk of injury completely. However, it is important to recognise that personal fall arrest may be the most suitable, or only, option in certain circumstances.

Fall arrest equipment is used to arrest a fall should it occur, preventing the worker from hitting the ground (or other surface) or structure. The fall arrest equipment and anchorage points must be capable of withstanding the forces involved and minimising those forces to an acceptable level. Where a complete guardrail system cannot be implemented, a personal fall arrest system shall be continuously used by anyone on an elevated work area or platform. A personal fall arrest system typically includes equipment such as:

- Helmets
- Lanyards
- Energy absorbers
- Linesystems
- Inertia reels
- Connectors
- Anchorage points.

**IMPORTANT:** Before each use, the user shall inspect all components of the personal fall arrest system he will be using.

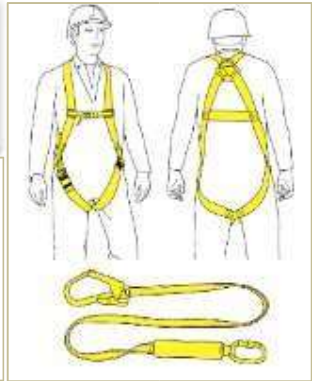

Figure 44: Personal Fall Arrest Equipment

**IMPORTANT NOTE:**

- The guidance provided in this section is intended to support and NOT to replace the requirements specified under Vedanta Corporate Safety Standard (and GN21) on Work at Height and Fall Protection.
- Businesses are advised to refer to the said standards for specific matters related to use of Collective Fall Protection and Personal Fall Arrest Systems and ensure compliance.

- Full body harnesses (including D-rings), lanyards (including snap hooks), lifelines, and other components of personal fall arrest systems shall be rated and labelled for a capacity of at least 2,300 kilograms (5,000 pounds) by the manufacturer.
- When used, personal fall arrest systems shall be attached by lanyard to a vertical lifeline, horizontal lifeline, or overhead structural anchorage capable of supporting 2,300 kilograms (5,000 pounds).
- Lanyards shall, if feasible, be tied-off to an anchorage point or lifeline that is high enough (preferably above shoulder height) to prevent the worker from free falling more than 6 feet (1.8 meters) or striking any lower level should a fall occur.
- Lanyards shall have a maximum length of 1.8 meters (6 feet). Two or more lanyards may be connected together (hook to eye) provided the total possible free fall distance is not more than 1.8 meters (6 feet). However, self-retracting lanyards (inertia reels) are preferred for these situations.
- Locking type snap hooks or carabiners with self-closing, self-locking keeper shall be attached to the end of each lanyard to prevent rollout. D-rings and snap hooks shall be compatible to prevent rollout.
- When lifelines are used, they shall be fastened to fixed safe point(s) of anchorage capable of supporting 2,300 kilograms (5,000 pounds), shall be independent, and shall be protected from sharp edges and abrasion. Safe points of anchorage may include structural members, but do not

## Guidance Note – Scaffolding Safety

include guardrails, standpipes, vents, other small diameter piping systems, electrical conduit, outrigger beams, or counterweights.

- Lifelines shall be made from 10 mm (3/8-inch) min. diameter wire rope. Other materials such as manila, nylon, or polypropylene rope shall not be used as a lifeline.
- Horizontal lifelines shall be installed at the highest feasible point, preferably above shoulder height. Horizontal lifelines shall be maintained with a sag at the centre no greater than 300 mm (12 inches) for every 10 meters (33 feet) of lifeline length between attachment points.
- Supervision shall ensure continuous monitoring of employees wearing a personal fall arrest system so that prompt assistance is possible in the event of a fall.
- Personal fall arrest system components shall not be used for any other purpose and shall not be re-used after stopping a fall or if any component has any sign of damage

### Hybrid Self-retracting Lanyards

Several manufactures offer self-retracting fall arrest lanyards that incorporate a mini inertia reel and energy absorber capability. These are designed such that they can be attached to an anchor point below foot level (e.g. in a fall factor 2 scenario.), similar to a fixed length fall arrest lanyard.

These self-retracting lanyards can be used as single or double (twin) lanyard systems where conventional fall arrest lanyards would be used. Therefore they are suitable for many routine scaffolding applications and can also be used for some tasks where an inertia line would be deployed (e.g. small cantilever structures such as a catch fit).

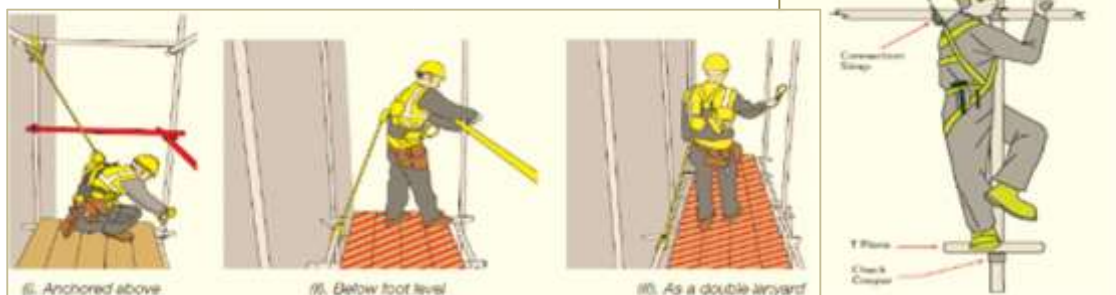

Figure 45: Examples of hybrid self-retracting lanyard systems in various scaffolding applications

By using these devices, fall distances can be reduced, trailing lanyard hazards minimised and greater flexibility is given to the scaffolder.

### Anchorage Points

Personal fall protection systems are totally reliant on being attached to a suitable anchorage. To ensure the safe performance of the system, the likely loads that would be transferred into the



anchorage, and the ability of an anchor point to resist/ withstand those forces without failure must be established.

It has been established, through independent testing, that steel tube and fitting TG20 compliant scaffolding can provide a safe anchor point for a scaffolder wearing a full body harness and attached by a lanyard with an energy absorber.

**IMPORTANT:** Where alternative scaffolding materials are used, such as, aluminium or glass reinforced plastic (GRP), the users must contact the supplier to ensure anchorage to the structure is appropriate.

### Unsuitable Anchor Points

- Ledgers or guardrails supported with putlog clips (single couplers);
- Ledgers or guardrails within a bay where it has a joint;
- Standards unless a suitable anchor device is used designed for the purpose;
- Standards with a joint between the lift and the attachment point;
- Puncheons;
- Transoms at foot level or below;
- Putlog transoms or bridle tubes;
- Underslung tubes below ledgers on non-load bearing couplers;
- Reveal or prop tie assemblies;
- Vertical braces (e.g. façade or ledger braces) or other diagonal tubes (e.g. spurs or rakers);
- Other tube open ended or not supported either side of the attachment position e.g. protruding end of a transom, needle or dropper; and
- Standpipes, vents or other piping systems, electrical conduits, outrigger beams or counterweights.

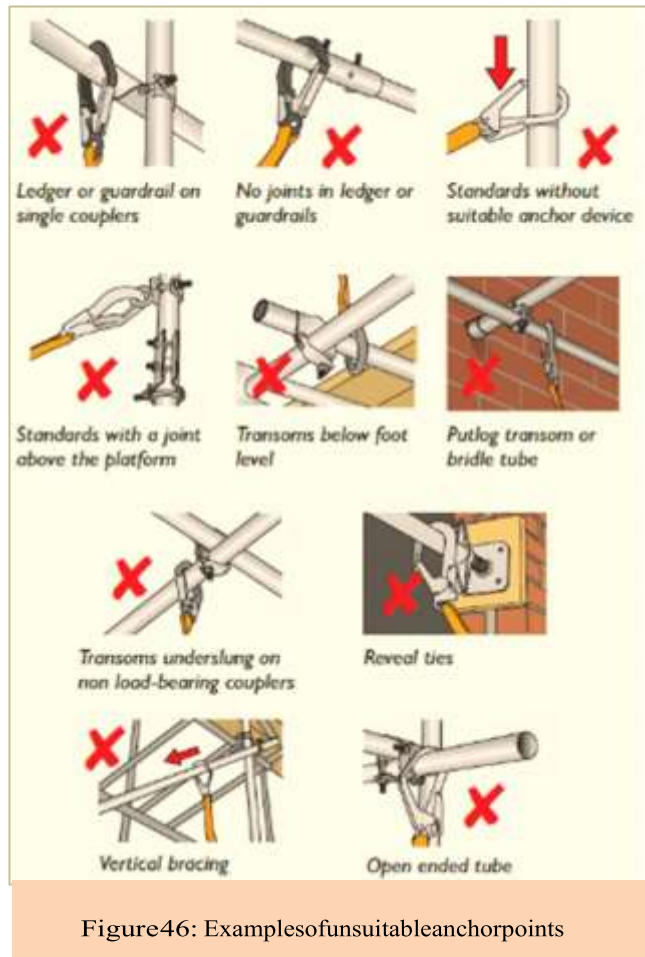

Figure 46: Examples of unsuitable anchor points

Suitable Anchor Points

- Ledgers and transoms supported with load bearing couplers
- Standards, but only when using a suitable anchor device designed for the purpose (see Figure 47) and no joints between the lift and the attachment point
- Guardrails supported with load bearing couplers (guardrails within a scaffold structure)
- Plan braces (horizontal) supported on right-angle couplers

Anchoring to scaffolding standards

Proprietary anchor devices for anchoring to scaffolding are now available that enable scaffolders to attach their lanyard to vertical standards (see Figure 48).

This means that scaffolders can take advantage of a higher anchor position in preference to attaching to the ledger below their feet.

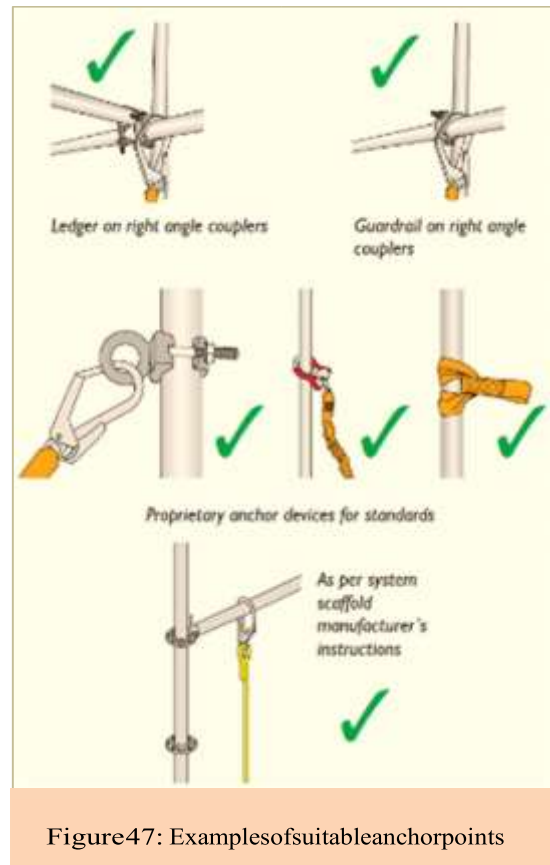
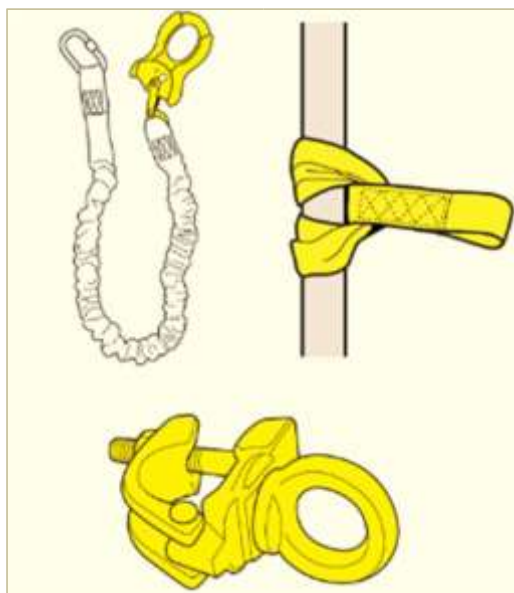

Figure47: Examples of suitable anchor points



Karabiners that are designed especially for attaching to scaffold standards make an effective and efficient anchor device. Another design includes special couplers that can be pre-assembled on standards before they are erected as part of a planned system of work.

This provides scaffolders with alternative and convenient anchor positions as they access an unprotected area e.g. the protected traverse system of work (see Methods of constructing a scaffolders' safe zone in Annex F). Always refer to the manufacturers' instructions to ensure safe use.

Figure48: Anchor devices. Connector specifically for use as an anchor to scaffold standards

10.2.3 Access and Egress



## Guidance Note – Scaffolding Safety

- Every platform, gangway, run or stairs shall be kept free from any obstruction, material, rubbish and projecting rails and slippery conditions.
- Grease, mud, paint gravel or plaster or any such hazardous substances shall be removed from scaffolds immediately. To prevent slipping on the platforms, either sand or saw dust or other suitable material shall be spread.
- A safe means of entry and exit shall be provided and used whenever the elevated work area or scaffold platform is 0.6 meters (2 feet) above or below a point of access.
- Climbing of scaffold braces, runners/ ledgers, etc. is not permitted, except as required by scaffolder during scaffold erection, alteration, and dismantling.
- Whenever the horizontal travel distance exceeds 15 meters (50 feet), each elevated work area shall have at least two means of exit. A means of exit shall be provided at least every 30 meters (100 feet).
- The minimum clear headroom above scaffold platforms and landings shall be 1.8 meters (6 feet). Everywhere else, it should not be less than 2 metres.
- Access and egress to scaffolding must, so far as is reasonably practicable, be safe for workers when erecting, using and dismantling a scaffold.
- Common means of entry and exit include:
  - Temporary stairs or portable ladder access systems installed at the start of erection, progressed with the scaffold, and used by the scaffolder whenever possible,
  - Permanently installed platforms or ramps,
  - Personnel hoists—non-mechanical forms of exit e.g. a ladder or stair tower should be provided in case of emergency, and
    - Using the existing floor level of a building, if entry from there is safe.
- Stairs should be secured to the scaffold bay. If stairs cannot be self-secured to the scaffold, they should be lashed as unsecured stairs can be affected by wind and may be dislodged. If not secured, the designer or supplier should provide documentation illustrating the maximum amount of clearance allowed between the transom and the top and bottom of the stair module.
- Ensure the gap between the end of a stair module and a transom is as small as possible. Large gaps can lead to stairs dislodging and falling when a load is placed onto it. □ The standard prohibits the use of cross braces as a means of access.

### Ladders

- All scaffolds whose working floor is above 4 feet should have an access ladder (fixed, tubular or framed) fastened to the scaffold structure.
- Fixed industrial single ladders—not extension ladders—should be used for entry to or exit from a scaffold. Ladders should not be used as a work platform or to gain extra height to carry out work from a scaffold.
- Ladders may be used where entry to the working platform is needed by only a few people and where tools and equipment can be delivered separately to the working platform, for example by materials hoist, crane or a rope and gin wheel.
- Ladders should be within a separate ladder access bay of the scaffold wherever space permits.

- Ladders should be set up on a firm, level surface, be securely fixed and not used on scaffold bays to gain extra height above the scaffold structure.
- Fixed ladders should be provided for flights above 4 m. Fixed ladder should have landings of minimum 600 mm extent at intervals not greater than 6'0 m. The width of ladder shall not be less than 300 mm and the runs shall be spaced not more than 300 mm.
- If the access bay is part of the working platform a self-closing trap door should be provided.

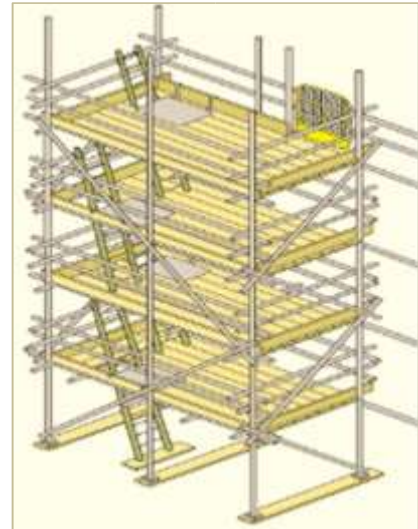

Figure 49: Ladder access bays with single-lift ladder

Where possible ladder entry should be located away from the working platform to prevent people falling through openings.

Strict controls should be implemented to ensure that trap door remains closed while working from the platform.

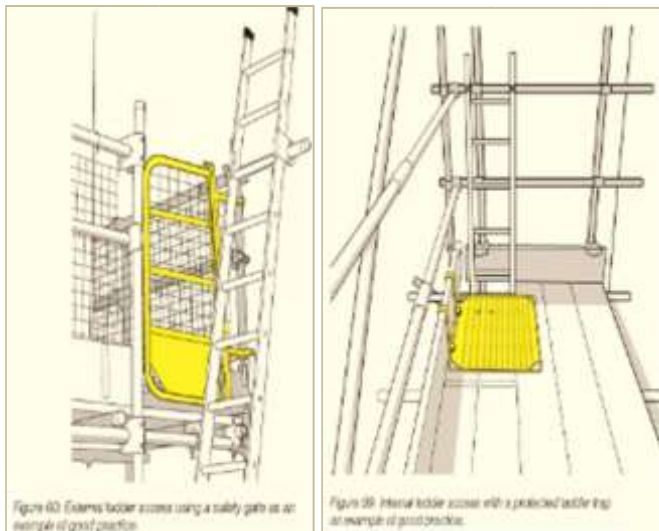

Figure 50: (1) External ladder access using a safety gate (2) Internal ladder access with a protected ladder trap door

- Ladder (or stair) access must:
  - be present on every floor; and
  - be accompanied by an inward opening self-closing swing gate, self-closing hinged trap door or other fall prevention system. The hinged trap door must be installed in a way that will not cause a risk of tripping or falling.
- Portable ladders are recommended for heights below 4m only. They should be placed at an angle of approximately 75 degrees from the horizontal. □ Both top and bottom

should be secured to prevent displacement, and the ladder rails should be extended at least 1 m above the top landing.

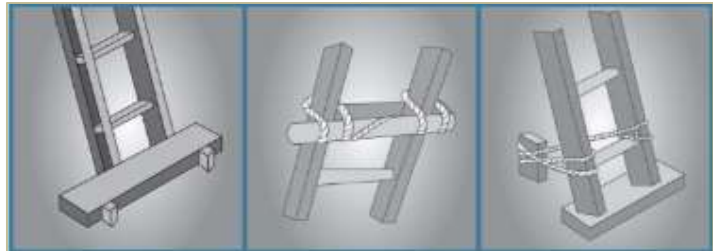

Figure 51: Ways to secure ladders

## Stairways

For scaffolds exceeding 4 m height, stairways are the safest means of access.

Where provided, stairway should conform to the following requirements:

- Treads and risers should be of uniform width and height in any one flight,
- Minimum width of 1 m,
- No unbroken vertical rise of more than 4 m,
- Maximum angle of ascent 50 degrees,
- Stair railings on all open sides,
- Hand rails on all enclosed sides, and
- Standard railings and toe-boards on all landings.

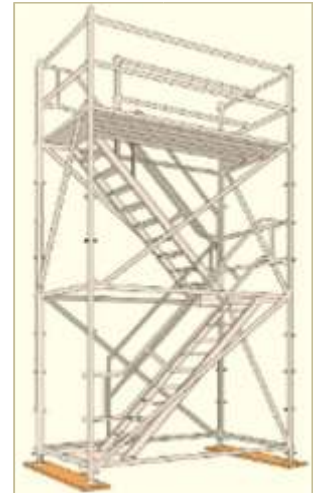

Figure 52: Typical proprietary system scaffold stairway

## Sloping Platforms and Barrow Ramps

Sloping platforms may be used to access scaffolds and other structures. They should have platforms and edge protection that comply with these guidelines. Barrow ramps contain cleats alongside an un-cleated board or channel. This allows wheelbarrows or wheeled loads to be moved easily while guarding against slipping.

- For heavy loads (such as a concrete-laden wheelbarrow), gradients of about 1:12 are appropriate.
- The maximum recommended slope for a cleated barrow ramp is 20 degrees or around 1:3

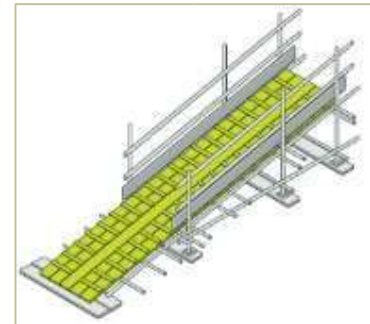

Figure 53: Barrow Ramp

## Pre-fabricated Scaffold Access Frames

Integral prefabricated scaffold access frames (such as H-frame) may be used in place of ladders/ stairs as means of access. However, they need to meet the following minimum requirements:

- Be specifically designed and constructed for use as ladder rungs;
- Have a rung length of at least 8 inches (20 cm);
- Not to be used as work platforms when rungs are less than 11.5 inches in length, unless each affected employee uses fall protection, or a positioning device;
- Be uniformly spaced within each frame section;
- Be provided with rest platforms at every 35-foot (10.7 m) maximum vertical intervals on all supported scaffolds; and
- Have a maximum spacing between rungs of 43 cm. In case of joining end frames, the resulting spacing may be permitted to vary, but in no case, exceed 43 cm.



Figure 54: Using the end frames of an H-frame scaffold for climbing

### 10.3 Physical Hazards:

#### 10.3.1 Overhead and Underground Electrical Sources

Electrical power sources, whether overhead or underground, poses significant risks including electrocution, arcing, explosion or fire causing burns, unpredictable cable whiplash and other objects being electrified like signs, poles, trees or branches. Construction work carried out on or near energised electrical apparatus or services is high risk activity and a Safe Work Method Statement must be prepared before this work starts.

The following should be considered when working near electric lines:

- Are workers, plant, tools or the scaffold likely to go near electric lines? If so, how close are they allowed to be?
- Has the relevant electricity supply authority been contacted for information about specific requirements when working near electric lines including the qualifications required for those people working near electric lines?
- Is there a safety observer in place to watch plant when it is moving and is likely to come close to electric lines?
- Are unauthorised person zones, authorised person zones and exclusion zones in the work area set up?
- Are emergency rescue procedures in place including calling the electricity supply authority to isolate the electricity supply before trying to rescue a person who has received an electric shock?

As a general rule, it is recommended that a minimum clearance distance of 4 metre is maintained for metallic scaffolding used near overhead electric lines, in all directions. In the case of 220 kV lines the minimum clearance should be 6 metres. However, actual safe working distances will depend on the type of work being carried out and the voltage and the insulation status of the electric lines. Contact the relevant electricity supply authority to determine the type of control measure needed. This may include isolating the line.



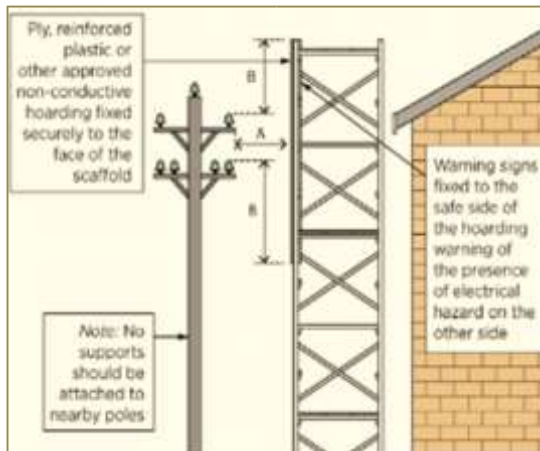

Figure 55: Non-conductive Hoarding for Scaffolds

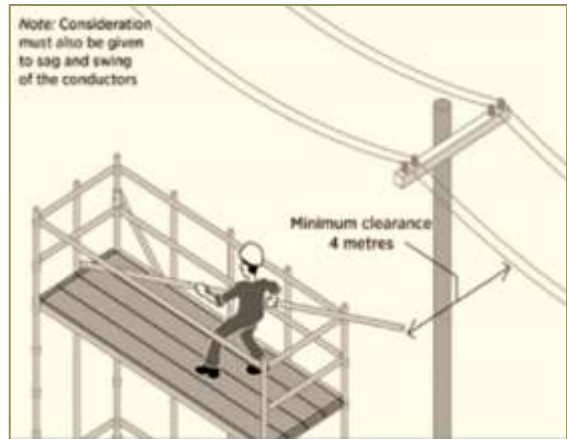

Figure 56: Approach Distances for Metallic Scaffold

Insulated Lines		
Voltage	Minimum Distance	Alternatives
Less than 300 volts	1 meter (3 feet)	2 times the length of the line insulator, but never less than 3 meters (10 feet).
300 volts to 50 kV	3 meters (10 feet)	
More than 50 kV	3 meters (10 feet) plus 100 mm (4 inches) for each 1 kV over 50 kV.	
Uninsulated Lines		
Voltage	Minimum Distance	Alternatives
Less than 50 kV	3 meters (10 feet)	2 times the length of the line insulator, but never less than 3 meters (10 feet).
More than 50 kV	3 meters (10 feet) plus 100 mm (4 inches) for each 1 kV over 50 kV.	

Reference: OSHA 3150, Revised 1998, *A Guide to Scaffold Use in the Construction Industry*

Where abovementioned controls (de-energisation, LOTO and/ or safe distances) cannot be effectively implemented, a written safe work method statement should be prepared and approved as part of the permitting process, prior to commencement of work.



The method statement should clearly establish the engineering (e.g. insulation/ isolation), system-based (e.g. safety observers) and people based controls (e.g. warning signs, PPE) to prevent and mitigate the risks of exposure to live electrical parts, while working on scaffold located near live conductors.

### Earthing of Scaffolding

Electrical hazards in the form of lightning, overhead electrical lines and integral lighting and alarm systems can affect all types of structures and if scaffolding is not properly earthed, people can be killed or seriously injured and buildings damaged.

Although the scaffolding structure is usually in contact with the ground and may have base plates and sole boards, it should never be assumed that the structure is effectively earthed.

Where the scaffolding carries lighting, alarm or similar small power circuits, it is recommended that the structure should be electrically bonded to the protective conductor(s) of the circuit(s) that it carries. It should be noted that individual scaffolding structures if not connected (or effectively bonded), must be earthed separately.

### 10.3.2 Powered Mobile Plant and Traffic

Powered mobile plant and vehicular traffic are hazards which can potentially affect worker safety and the safe use and structural integrity of a scaffold. Control measures to minimise the risks, so far as is reasonably practicable, associated with moving plant and traffic include:

- Re-routing vehicles and mobile plant away from where the scaffold is located e.g. by using traffic controllers to redirect traffic
- Using barricades, signs, posts, buffer rails, guards, concrete or timber kerbs to prevent mobile plant and traffic from coming into contact with a scaffold, and
- Ensuring the scaffold does not have unnecessary protrusions e.g. over-length transoms, putlogs, tie tubes or over-height standards.

### 10.3.3 High Winds

- Personnel shall not be on any scaffold or other temporary elevated work area during storms or high winds – sustained winds more than 65 kph (40 mph) - unless the scaffold or working level is indoors or otherwise unaffected by the weather conditions.
- Outdoor scaffolds or elevated work platforms shall not be used during thunderstorms or when there is likelihood of lightning.

### 10.3.4 Work over Water

- Where men work on, over, or near water, a guardrail system shall be provided. Wherever a guardrail system is impractical, or when men are outside the protection of these safeguards, a personal fall arrest system shall be worn.

- An approved personal flotation device (life vest) shall be worn at all times by each person working above or near water. Personal flotation devices shall be inspected prior to each use.
- Flotation rings shall be provided at intervals not greater than 15 meters (50 feet) apart when personnel are working above or near water. The number of flotation rings and the length of the rope depend on the location and the vertical distance above the water.
- A continuous man-watch shall be provided when personnel are working above or near water.

### 10.3.5 Hot Surfaces

- Suitable precautions shall be taken to prevent workers from coming into contact with any hot surface. Barriers shall be erected. Signs shall be posted warning: “Hot Surfaces.”
- If the same is not possible, then a standby man shall be assigned to warn other workers of the hazard.

## Guidance Note – Scaffolding Safety

### 11. SCAFFOLD INSPECTIONS AND TAGGING

#### 11.1 Scaffold Inspections

All scaffolds must be inspected by competent user on a daily basis (while in use), as part of pre-start check.

The scaffold and its supporting structure is required to be inspected by a competent person:  Before it is taken into use (after erection prior to hand over);  Before use of the scaffold is resumed:

- o after an incident occurs that may reasonably be expected to affect the stability of the scaffold (say impacts and damage),
- o After exposure to bad weather (rain, storm, high winds etc.)
- o Following modifications/ repairs; (an engineer must check the design if the strength of the supporting structure cannot be verified, or the structure has been engineer designed.)

- At least every 7 days while in use; and
- At least every 30 days while set up and not in use.

If an inspection indicates that a scaffold at a workplace or its supporting structure creates a risk to health or safety, the person with management or control of the scaffold must ensure that:

- Any necessary repairs, alterations and additions are made or carried out, and
- The scaffold and its supporting structure are inspected again by a competent person before use of the scaffold is resumed,
- Unauthorised access to the scaffold is prevented while the scaffold is incomplete or unattended.

Scaffold re-inspections must be completed any time when conditions may have changed causing the integrity of the scaffold to be suspect.

#### 11.2 Scaffold Tags

All scaffolding must have a tag system that:

- meets applicable regulatory requirements;
- identifies whether the scaffold is fit for purpose or not;
- identifies whether the scaffold is authorised for use or not; and
- Uses a standardized colour coding and lettering system with a unique scaffold identification tag number for tracking purposes.

Inspection and tagging of scaffolds should be performed only by an authorized scaffolding supervisor.

Green - tags will be hung on scaffolds that have been inspected and are safe for use. A



green "SAFE FOR USE" tag(s), and should be attached to the scaffold at each access point after the initial inspection is complete.

Yellow - "CAUTION" tag(s), will replace all green "Safe Scaffold" tag(s) whenever the scaffold has been modified to meet work requirements, and as a result could present a hazard to the user. This tag indicates special requirements for safe use.

The YELLOW tag, as a minimum requirement, will have:

- Potential hazard(s) marked on the reverse.
- The preventative measures that must be taken prior to use to mitigate the hazard marked on the reverse.
- The name of the client company representative authorizing the use of the Yellow tagged scaffold.



The yellow tag should not to be removed until the scaffold has been returned to a safe condition and an inspection by a “competent person” has been completed. Based on the results of that inspection the appropriate tag (red or green) will be hung on the scaffold and the yellow tag removed.

NOTE: Use of the “yellow tag” status is not intended to override the green tag system. All efforts should be made to return the scaffold to a “Green Tag” status as soon as possible.

Red " DANGER – UNSAFE FOR USE" tag(s), will be used during erection or dismantling when the scaffold is left unattended and replace all green "Safe for Use" tag(s) or yellow "Caution / Hazard" tag(s) in the event a scaffold has been deemed unfit for use.

The RED tag(s) as a minimum requirement will include:

On Front Side:

- The work order number or project number, and
- the inspection date and the name of the person who performed the inspection.

On Reverse Side:

- Status of whether; under erection, being dismantled, repairs required or overhead protection only, marked on the reverse.



### 11.3 Scaffold Handover

When the scaffolding has been inspected and deemed to be safe for use, the competent person (preferably an authorized structural engineer from the contractor or Vedanta) should issue a handover certificate (See Annexure E) to advise the user (Vedanta) client that the scaffold:

- has been built according to the agreed specification, duty rating, and any limitations on the use of the scaffold;
- has been left in a suitable condition for its intended use; and  complies with the relevant statutory requirements.

The person issuing the handover certificate should check that the scaffold is safe to use and provide the necessary tags for displaying on the scaffold (as discussed earlier)

The end user must make sure they are aware of and understand the intended use as well as the limitations on the scaffold. For suspended scaffolds, this includes how to perform the daily pre-start check (this information should be sought from the scaffold supplier/ manufacturer).

This certificate should be kept until the scaffold is further altered or dismantled.

### 12. EMERGENCY RESPONSE, RESCUE AND RECOVERY

Scaffolders may need to be rescued from height for a number of reasons, for example operatives who have suffered a heart attack on a working platform and those who have injuries as a result of slips/trips or pulled muscles. However, this guide focuses on those suspended in a harness following a fall. A scaffolder suspended motionless in a harness could soon start to suffer from physiological problems due to restricted blood circulation in the legs. This can lead to symptoms such as faintness, breathlessness, sweating, nausea, unusually low heart rate and ultimately unconsciousness. It is essential that systems of work and rescue plans, appropriate to the workplace, are set up so that no one will be in a position where they are likely to suffer from this condition, and appropriate rescue facilities should always be on hand to enable an immediate and safe rescue should the need arise. If a person falls and is suspended in their safety harness, restriction of movement or loss of consciousness must be anticipated, so they must be rescued extremely quickly. The aim should be to keep the post fall suspension time to a minimum by getting the person back to a position of safety as soon as possible.

An emergency plan must be prepared and maintained so that it remains effective for the workplace where work involving scaffolding is carried on. While preparing the emergency plan, the following must be taken into consideration:

- Can the work at height be avoided?
- What types of scaffold structure are to be provided?
- Can falls be prevented?
- Collective protection takes priority over personal protection
- Has the correct choice of personal fall protection equipment been selected?
- All parties should be clear about their own and others responsibilities regarding rescue
- Are your scaffolders capable of carrying out a rescue without putting themselves or others at risk and without specialist equipment?
- Are your scaffolders aware of the importance of swift action, the possible effects caused by suspension and what to do if rescue is required?
- Is the specialist equipment identified in the rescue plan available and are your scaffolders or others trained to use it?
- Does the selection of personnel and supervision match the complexity of job?

#### 12.1 Key Elements of an Emergency and Rescue Plan

- Written emergency procedures, including:
  - An effective response to an emergency,
  - Safe retrieval of personnel who has fallen,
  - Ensuring the safety of rescuers,
  - Location and means of accessing the rescuer(s),
  - Notifying emergency services at the earliest opportunity,
  - Medical treatment and assistance,



- Effective communication between the person authorised by the person conducting the business or undertaking to co-ordinate the emergency response and all persons at the workplace,
- Testing of the emergency procedures, including the frequency of testing,
- Information, training and instruction to relevant workers in relation to implementing the emergency procedures.

### Rescue can be effected in the following ways:

**Self-Rescue:** An act or instance of an employee using his fall protection equipment to rescue him or herself.

**Assisted Rescue without specialist rescue equipment:** Typically used in the event of a person falling from an independent, tower, birdcage scaffold, or any other structure where there is access adjacent to the suspended person;

**Assisted Rescue using Remote Rescue Equipment:** Typically used in the event of a person falling from a cantilevered/suspended scaffold or any other structure where there is no access adjacent to the suspended person. Such rescue equipment may include, retrievable inertia reel, Remote Rescue kits etc.

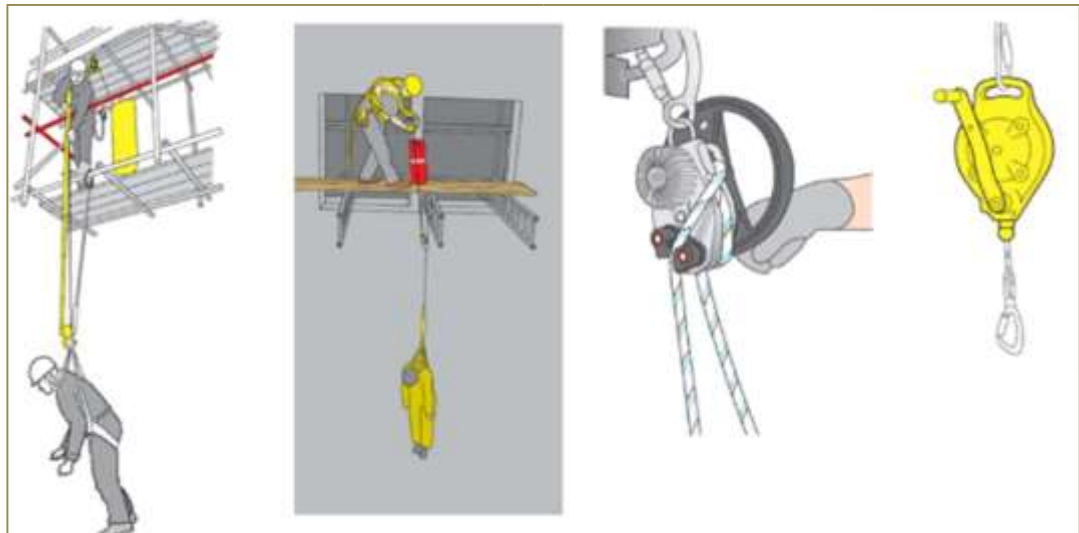

Figure 57: Examples of remote rescue equipment for scaffolding operations

**Assisted Rescue using Access Equipment :**

Typically used in the event of a person falling from a scaffold or any other structure and is suspended by their personal fall protection equipment. Such access equipment may include, Crane and Basket, Mobile Elevating Work Platforms, Ladders etc.

If an elevating work platform (EWP) or other access equipment is to be used for a rescue, it should be readily available and at all times be able to reach the position of the person using the fall-arrest system.



Figure 58: Scaffolder working without a fully-boarded platform

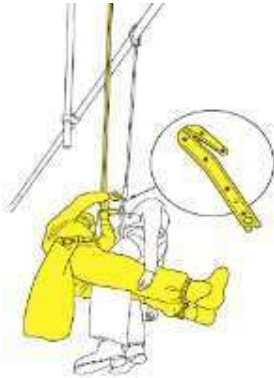

## Fully Assisted with Specialist Rescue Equipment:

Figure 59: Fully assisted rescue situation. Rescuer attaches casualty to himself and cuts off the lanyard webbing.

To be used ONLY in the event of a person falling from height and where there is no access adjacent to the suspended person, where they are suspended in free space and a safer form of rescue cannot be justified. Such rescue may involve use of Abseiling techniques and equipment (or, rope access).

In such rescue, equipment and techniques can be used that requires a rescuer to descend (or abseil) down to the suspended scaffolder, attach himself to the rescuer and then release the scaffolder's primary fall arrest device (e.g. lanyard). The rescuer may then either raise or lower the casualty to safety (depending upon the equipment used). This type of equipment and technique places a rescuer at greater risk and should only be considered as a last resort (see Figure 59).

Before starting work the permit issuing authority/ Vedanta supervisor should verify that:

- the rescue plan is appropriate and achievable, especially with respect to the path of a casualty and suitable anchor points;
- Scaffolders (and rescue personnel) are given documented training, covering the appropriate emergency rescue and recovery procedures and rescue equipment provided for the type of structure they are working on, to minimize the total rescue time
- Appropriate rescue equipment, anchorages and personnel are readily available at work location.

## 12.2 Rescue Training

Scaffolders and Supervisors should receive appropriate training and awareness in rescue procedures and how to plan and formulate an effective rescue plan. Employers must ensure when specifying specialist rescue equipment as part of a rescue plan, that an adequate number of scaffolders have been suitably trained in its use, including exercises as necessary. It is essential that periodic refresher rescue training is carried out at appropriate intervals.

Training should be repeated if circumstances change significantly on site e.g. new personnel, design changes, new equipment introduced etc. Refresher training should be provided on a regular basis to prevent skill fade.

### 13. TRAINING, COMPETENCY AND AWARENESS

A training needs analysis and training matrix should be developed and maintained for identifying and documenting the training and skill requirements for designers, supervisors, scaffolder, users etc.

General awareness training which is to include the hazards and risks associated with using or working near scaffold is imparted to all affected personnel.

### 14. SUPPLIER AND CONTRACTOR MANAGEMENT

Scaffold contractors (external parties) should be pre-qualified.

A Vedanta company representative to be appointed as a key contact for scaffold contractor whilst on site.

### 15. RECORDS

- All records of training, competence and Scaffolding authorisations shall be kept in the business' HSE database.
- Completed Risk assessments, Method Statements and Scaffolding Plans shall be referenced to the associated job number and stored for a period of five years electronically or as a filed hard copy.
- Scaffold Handover Certificates and periodic inspection reports by competent persons should be filed on site for such duration, as prescribed under local regulatory requirements (or at least for 6 months after the date of dismantling of the scaffold, whichever is higher).
- All other records such as design modifications to, and specifications for, scaffolding, plant and work processes associated with scaffolding work; shall be stored in HSE database.

REFERENCES

Doc. Ref.	Description
OSHA : 29 CFR Part 1926	Safety Standards for Scaffolds Used in the Construction Industry
BOCW Act, 1996 and Central Rules,1998	Rules no.188 – 205 related to Scaffolding Safety
IS 2750 :	Steel Scaffoldings
IS 3696 :	Safety code of scaffolds and ladders: Part 1 Scaffolds
IS 3696 :	Scaffolds and Ladders - Code of Safety - Part 2 : Ladders
IS 4014 :	Part 1 Code of practice for steel tubular scaffolding Part 1 Definitions and materials
BS 5973:1993	Code of practice for access and working scaffolds and special scaffold structures in steel
EN 12811 Part 1, 2004:	Temporary works equipment – Scaffolds – Performance requirements and general design
IS 4014 : Part 2	Code of Practice for Steel Tubular Scaffolding - Part II : Safety Regulations for Scaffolding
IS 13416 : Part 1	Recommendations for preventive measures against hazards at workplaces Part 1 Falling material hazards prevention
EN12811 Part 2, 2004:	Temporary works equipment – Part 2: Information on materials
BS EN 12810-2:2003	Facade scaffolds made of prefabricated components
AS/NZS 1576	Scaffolding Series
ANSI/ASSE A10.8-2011	Scaffolding Safety Requirements

Annexure A

Scaffold Illustrations

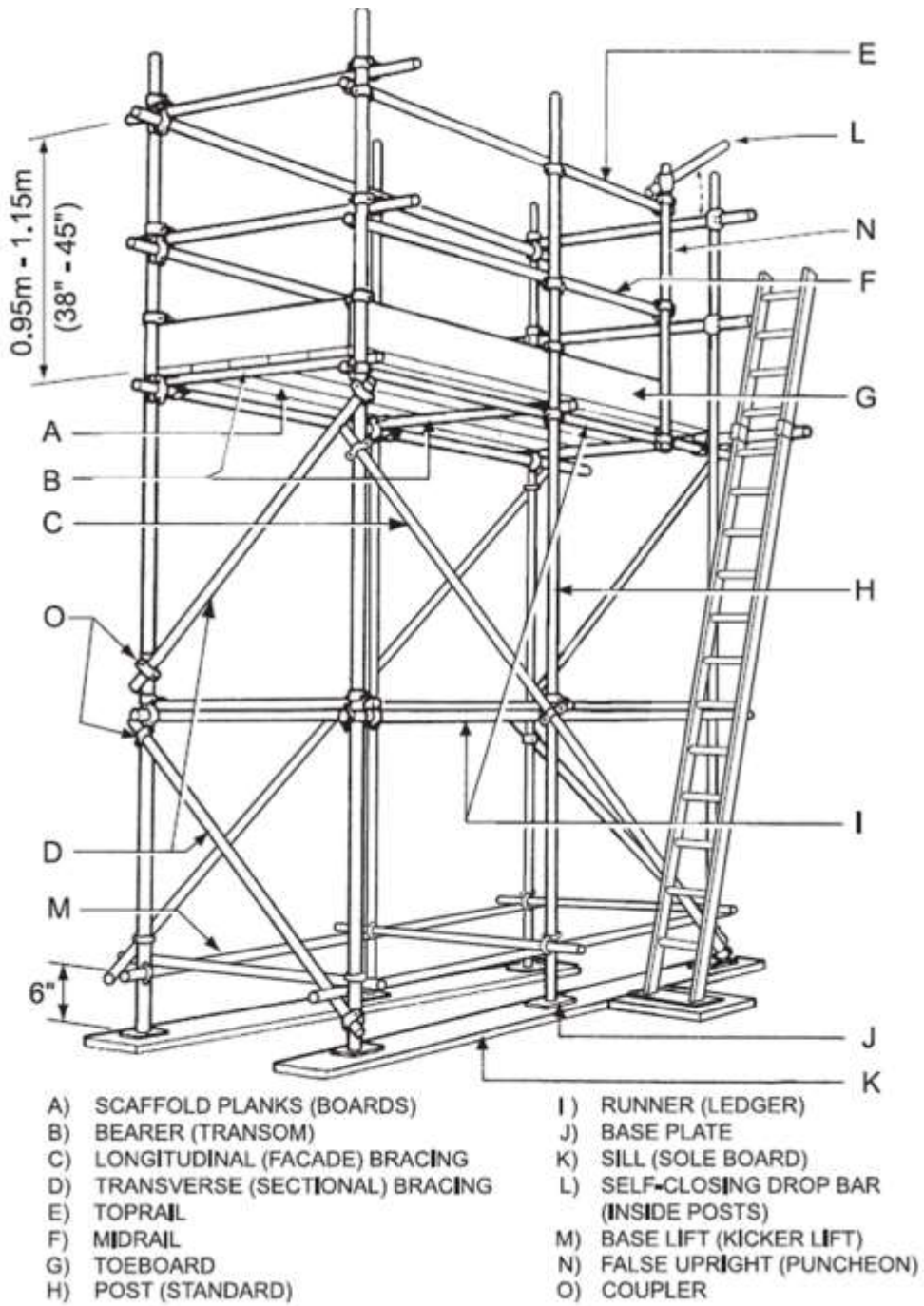



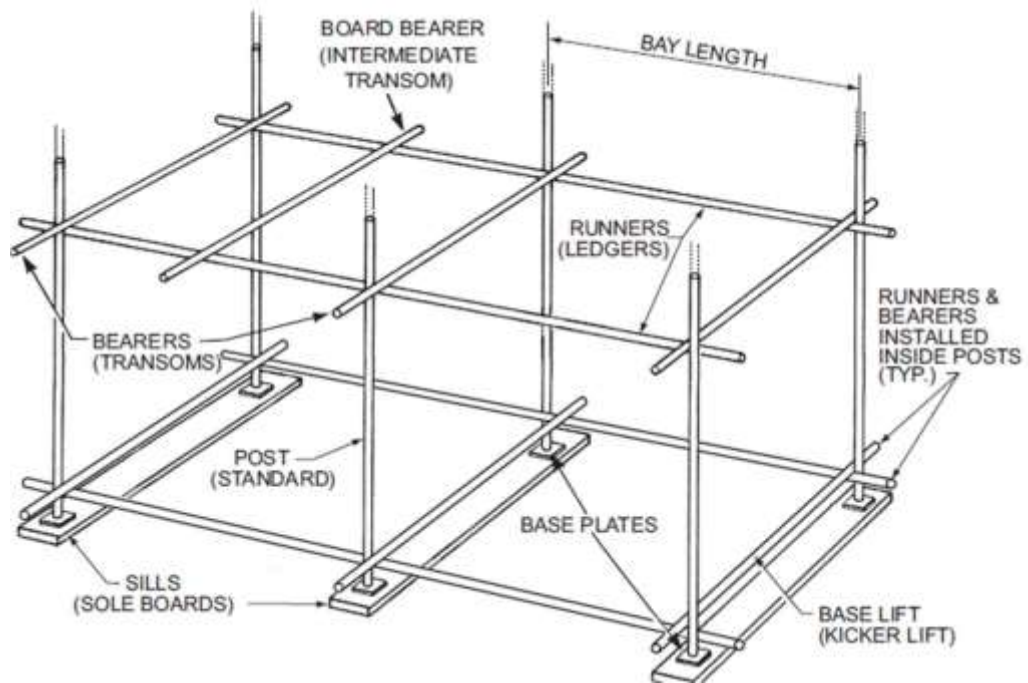

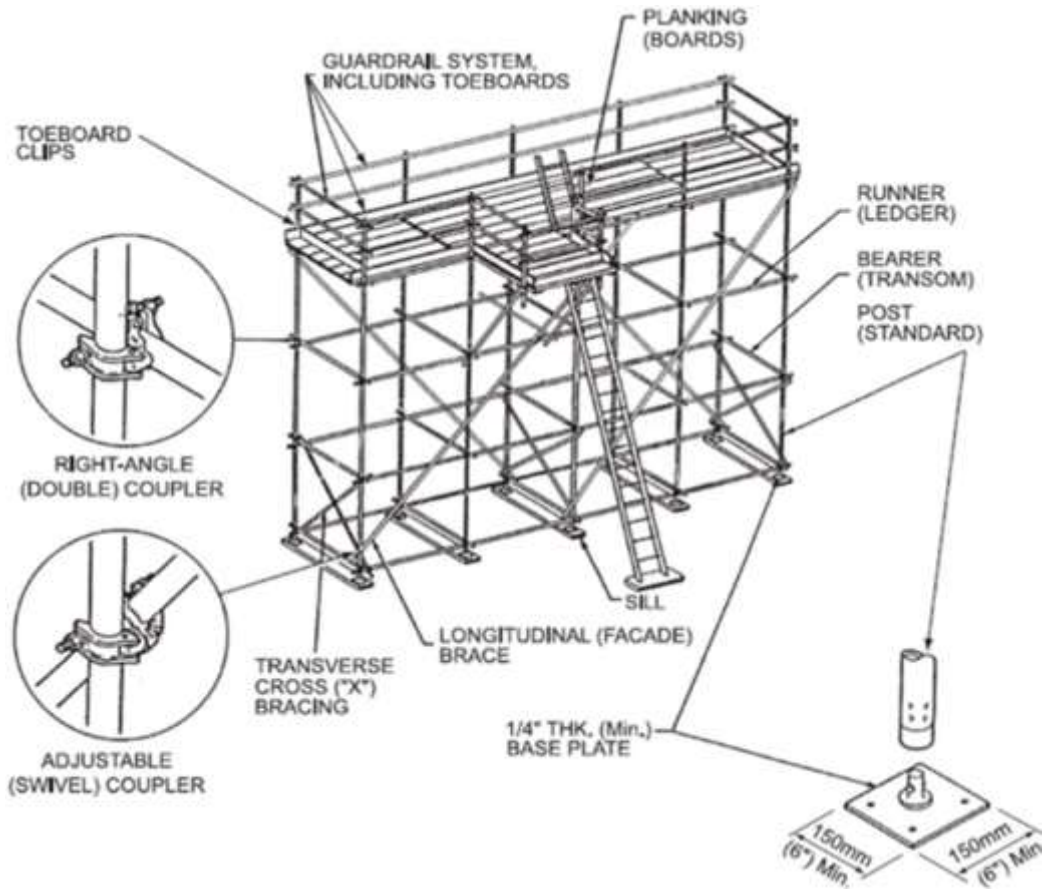

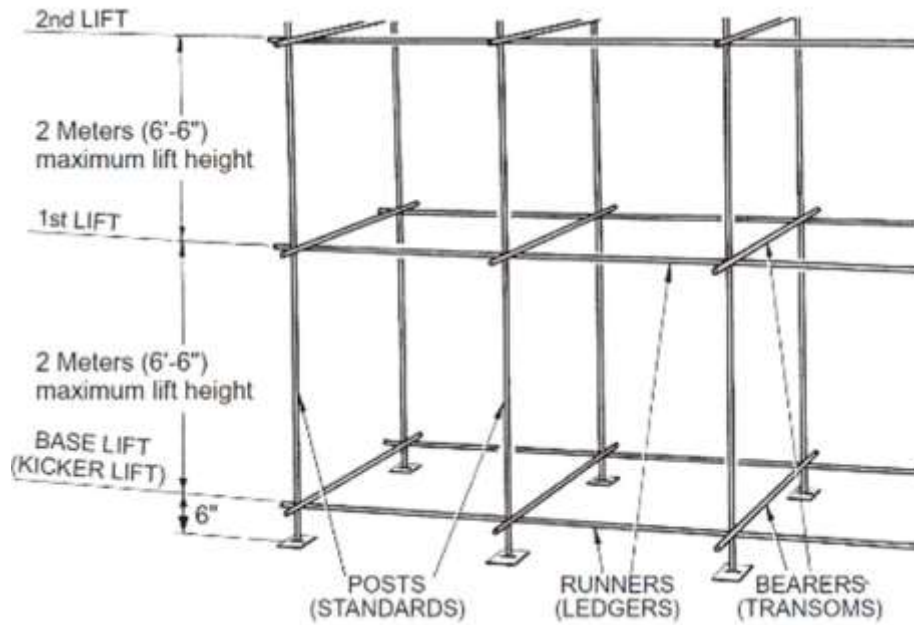
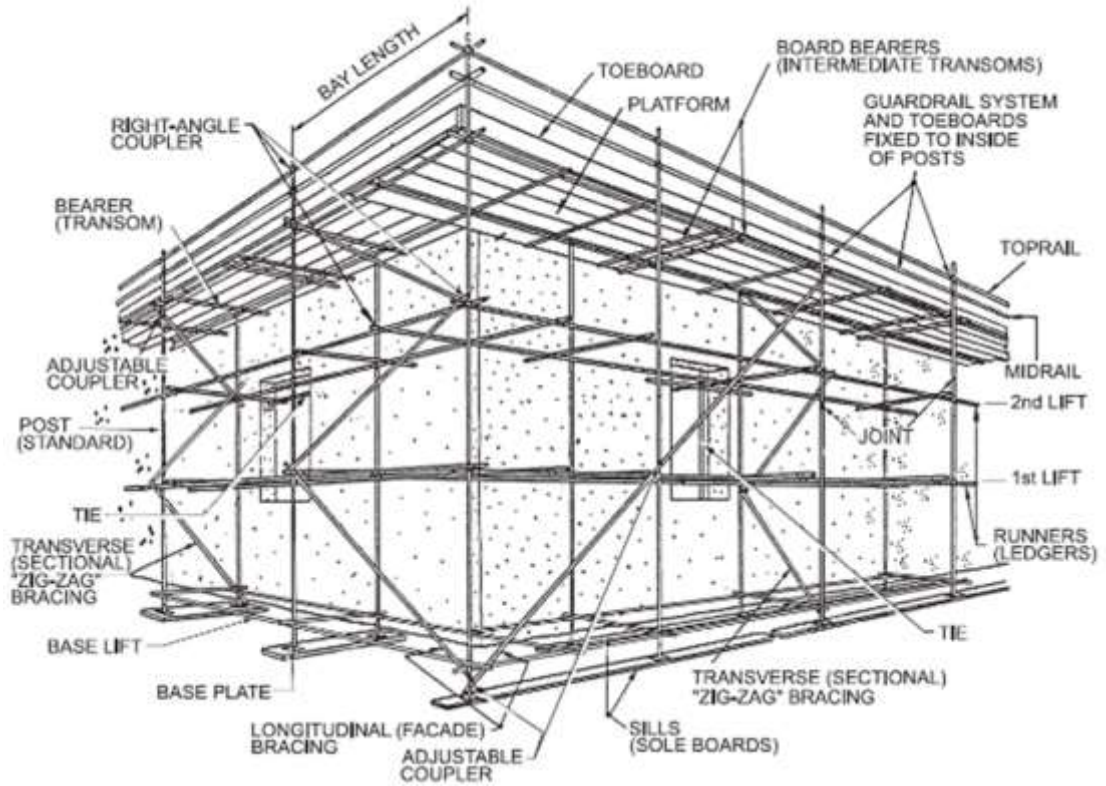

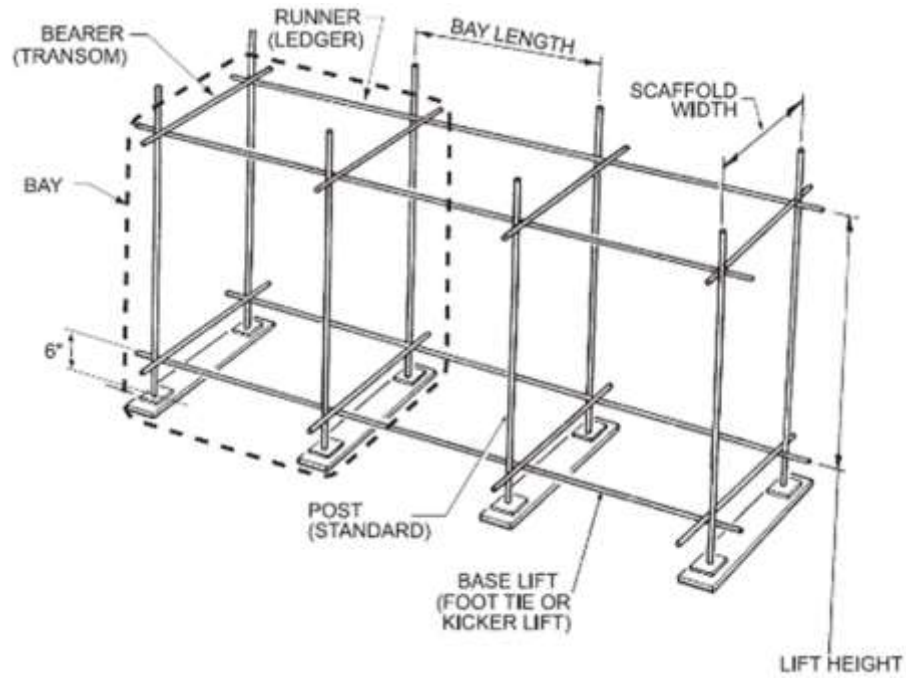

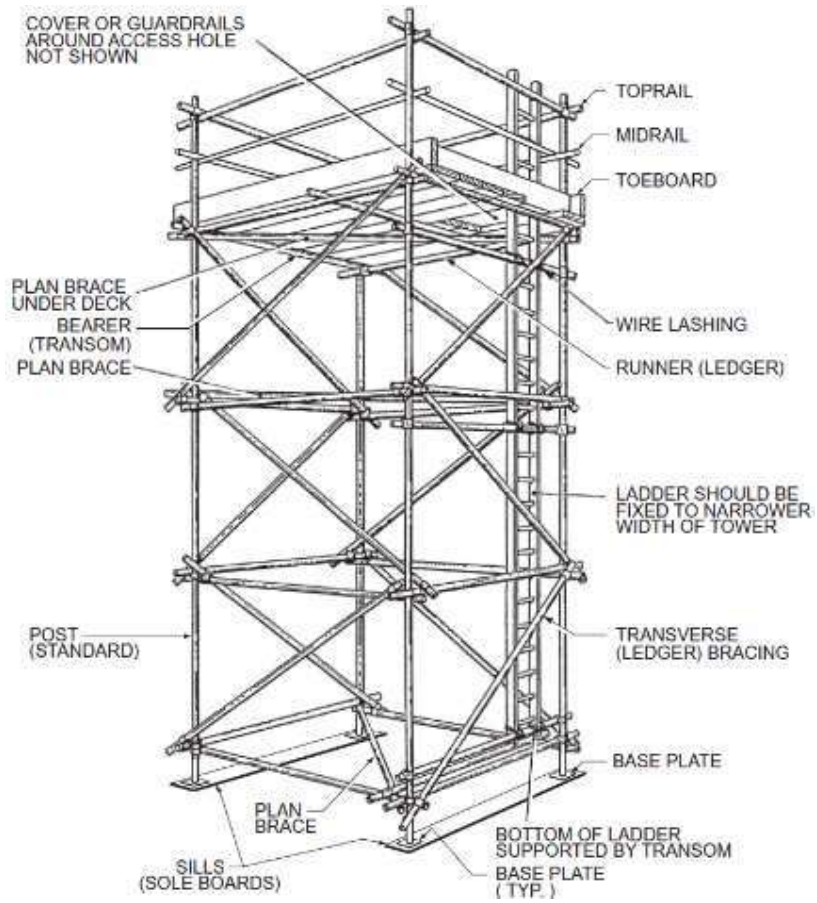

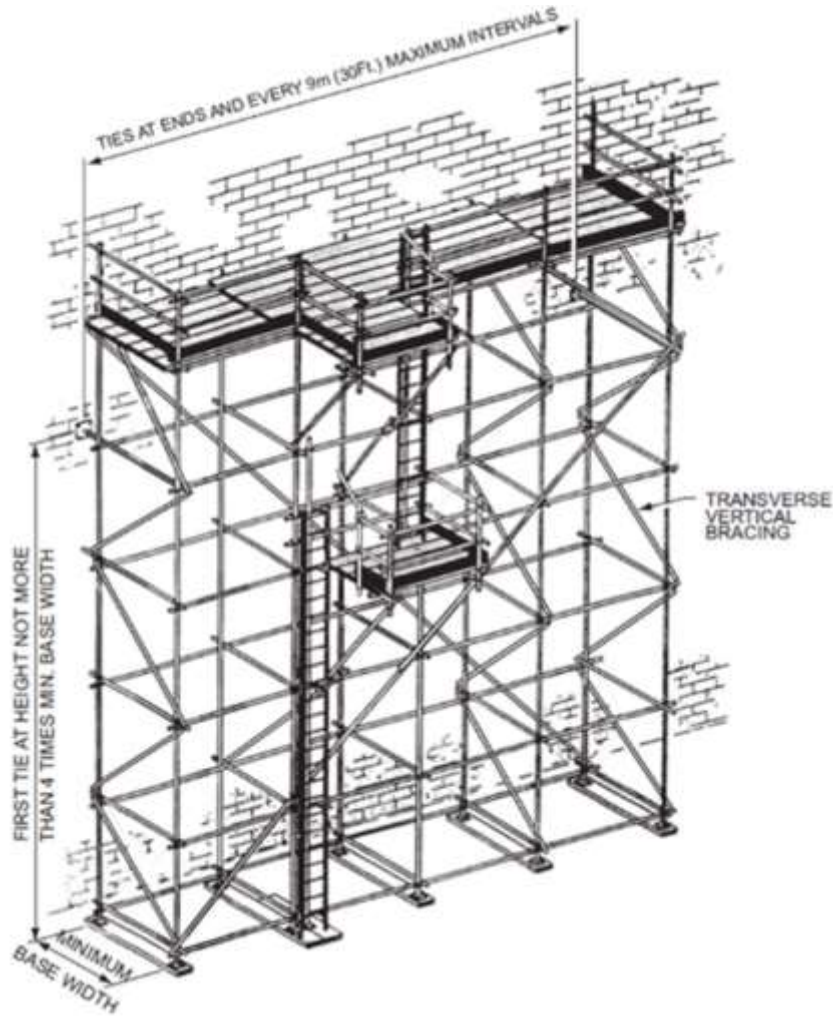

Bracing Illustrations



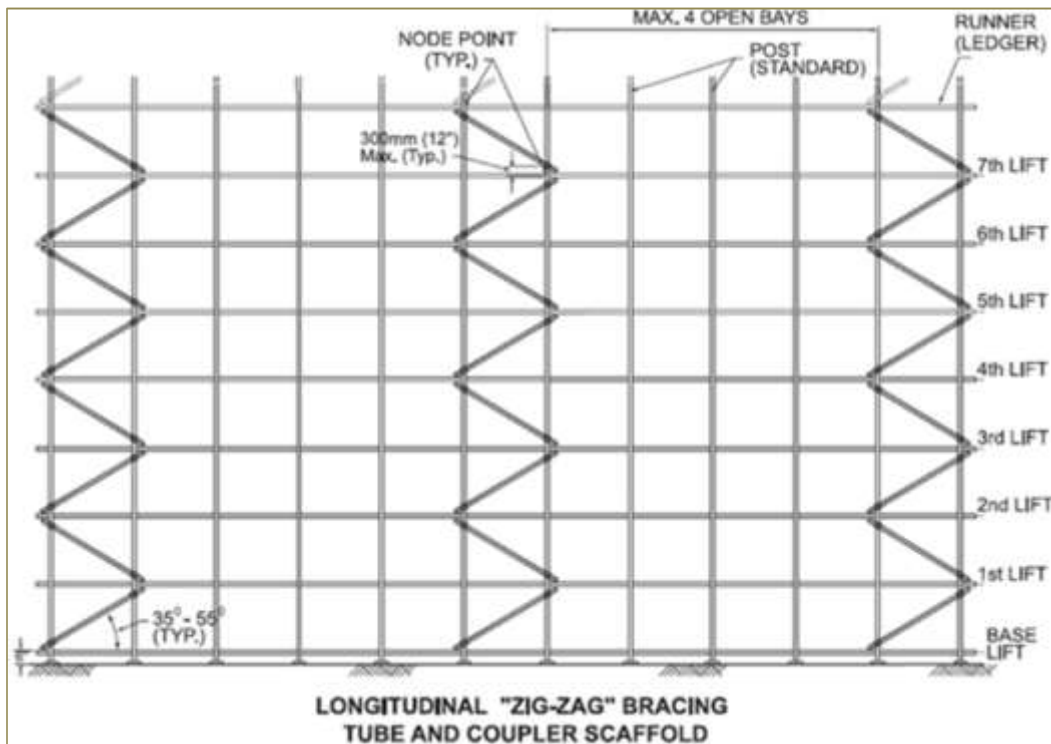
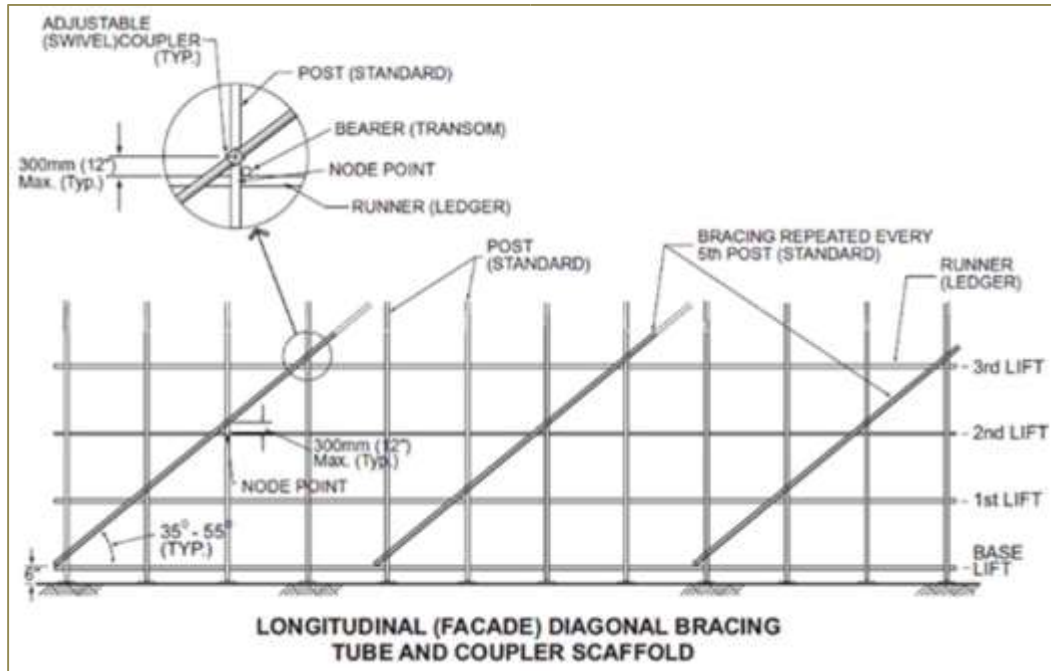

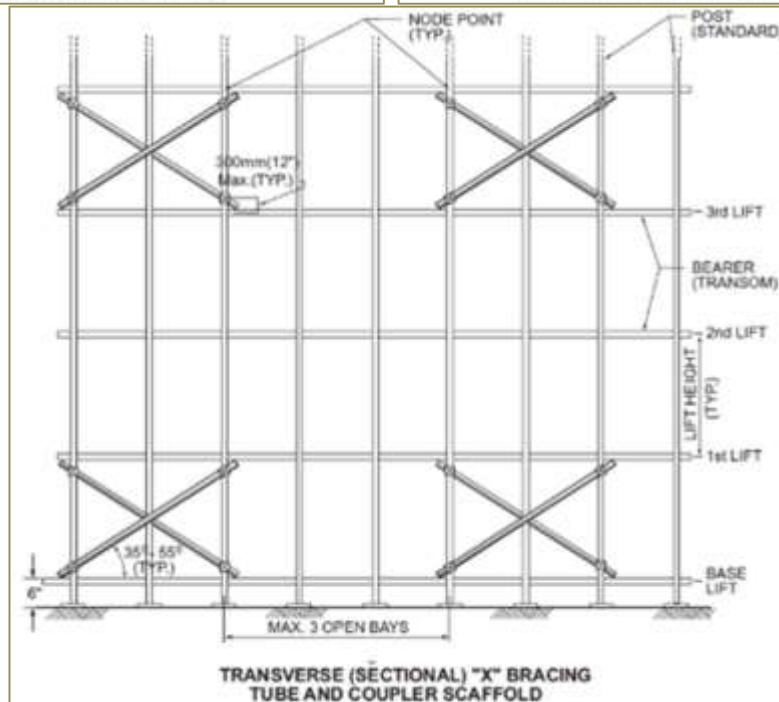
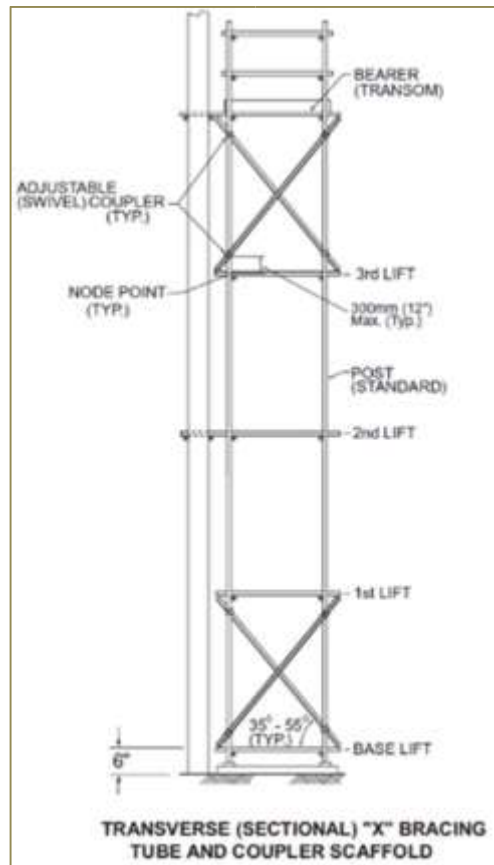
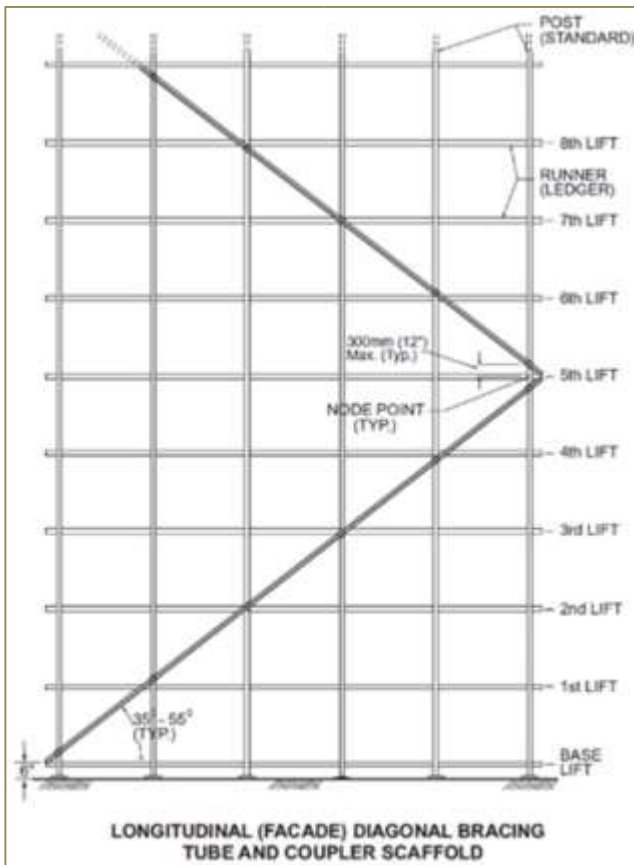

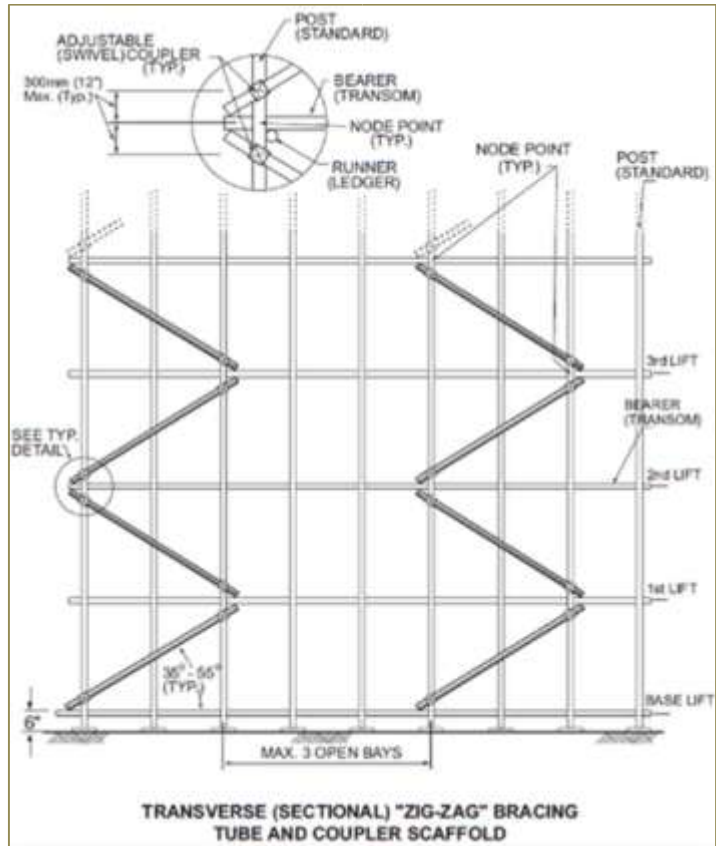
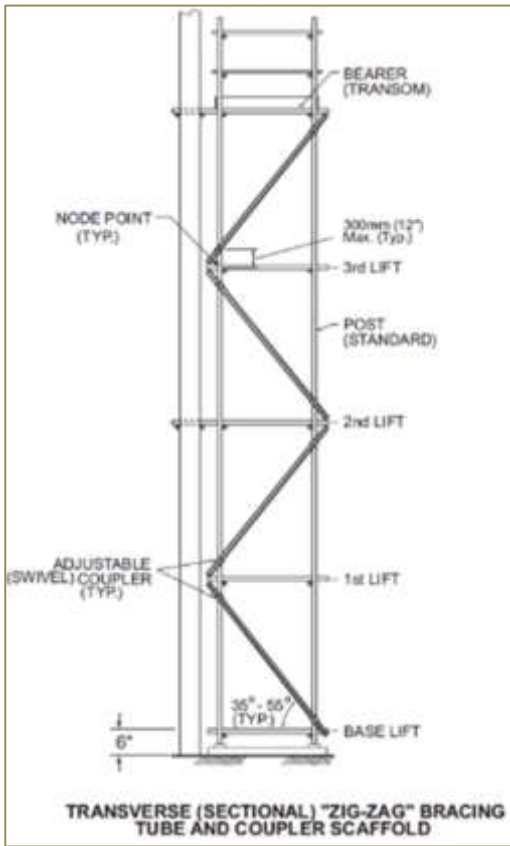

Annexure B:

## Guidance Note – Scaffolding Safety

**Cup-lock Systems Scaffolding :**  
Commonly made from galvanized steel, cup lock systems scaffolding is popular for its ability to support heavy loads.

With cup locks at every 500mm to 1,000mm, this type of scaffolding creates highly standardized systems that work well for scaffolding designs with repeated patterns.

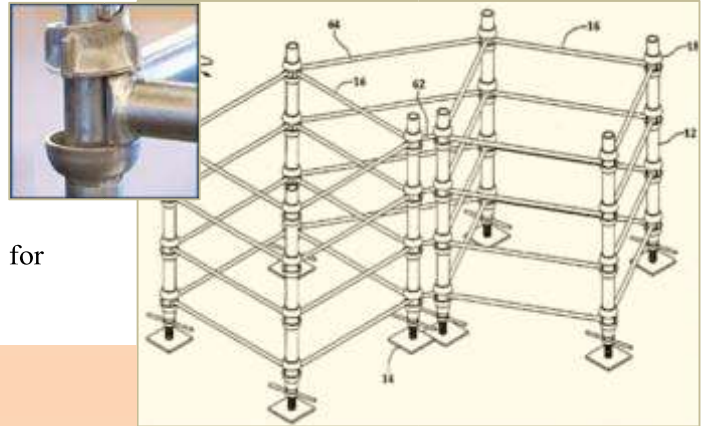

Figure60: Cup-locksystem



Figure61: Kwik-stage

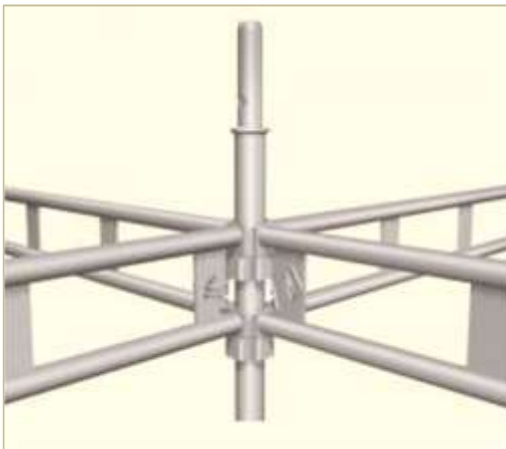

Figure62: HAKIScaffoldings

**HAKI Scaffolding :** HAKI is both a name for the manufacturer and a non-generic scaffolding system. Based on safety, quality, and adaptability, HAKI scaffolding is lighter and has fewer components than other systems.

The typical Bay length measures up to 3 meters and the system is approved for load class 6, making it into one of the more durable systems.

**Kwik-stage Scaffolding:** From commercial to residential applications, Kwik-stage is both easy to erect and relatively adaptable. With minimal components required, it's easy to assemble and disassemble. Non-slip platforms

and double guard rails included with Kwik-stage improve its safety and reliability.



**Ring-lock System Scaffolding:** Ring Lock Systems Scaffold is one of the simplest, most dynamic scaffold products used commonly in building construction and ship building. Its unique design allows for easy adaptation to virtually any structure, inside and outside.

Figure63: Ring-lock Scaffolding

**Quick-lock System Scaffolding:** Quick Lock Scaffolding System include Parts and Components of Vertical Leg Post and Horizontals. It is a type of quick erect scaffolding System. Quick lock scaffolding is popular used as slab formwork and shuttering support in construction and concreting. It is convenient to compatible with all parts and beams, accessories during concrete forming.



Figure64: Quick-lock Scaffolding

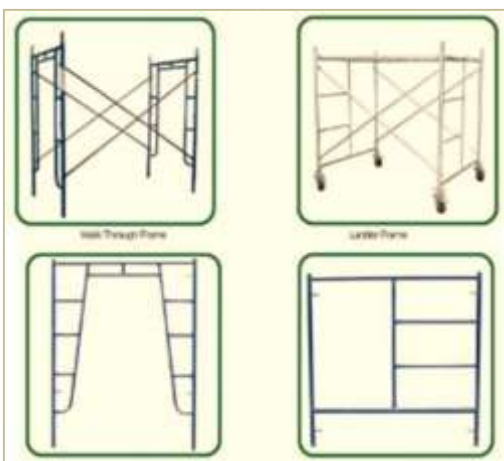

**Frame and Brace Scaffolding :** This type of modularized scaffolding consists of frames, braces, planks, and bases. This scaffold is very light and can be erected very quickly. However, it is unsuitable for heavy duty purposes. Types include: Walkthrough, H-Frame Scaffolds.

Figure65: Frame and brace scaffolding



Annexure C

Safe Scaffolding Checklist

Scaffold Vicinity	Yes	No	NA	Remarks
Has protection for other workers been provided? (Clear zones, screens etc.)				
Have sufficient safeguards against overhead electric lines been provided?				
Is there sufficient control over vehicle/mobile plant movement?				
Is there sufficient control over crane operation(s)?				
Are there sufficient controls for the storage, handling and use of hazardous substances?				
Are scaffolds erected a safe distance away from trenches or excavations?				
Supporting Structure	Yes	No	NA	Remarks
Is the supporting structure in good condition?				
Does the supporting structure have adequate strength?				
Are there sufficient controls to prevent deterioration of the supporting structure?				
Are all measures to strengthen the supporting structure adequate?				
Is the risk of the supporting structure being overloaded from other sources adequately controlled?				
Is the scaffold built on solid ground? If built on soft ground, are soleboards used to properly distribute the load?				
General Fitness for Purpose	Yes	No	NA	Remarks
Is there adequate provision for material handling?				
Are the clearances between the scaffold and adjacent structures correct?				
Is there adequate protection from falling debris?				
Has the scaffold been adequately designed to support all attachments?				
Are all approaches and platforms effectively lit?				
Sole-boards and Baseplates	Yes	No	NA	Remarks
Are there sufficient sole-boards?				
Are the sole-boards of suitable material and in a serviceable condition?				
Are the sole-boards secure?				
Are there sufficient baseplates?				
Are the baseplates of the appropriate type?				

# Guidance Note – Scaffolding Safety



Are the baseplates serviceable and of suitable dimensions?				
Are the baseplates secure?				
<b>Access and Egress</b>	<b>Yes</b>	<b>No</b>	<b>NA</b>	<b>Remarks</b>
Is there safe access and egress to every scaffold platform?				
Are temporary stairways correctly installed?				
Are portable ladders of an industrial grade, serviceable and correctly installed?				
Are access ways and access platforms correctly installed?				
<b>Scaffold Structure</b>	<b>Yes</b>	<b>No</b>	<b>NA</b>	<b>Remarks</b>
Are the standards bearing firmly?				
Are the standards plumb (or as designed)?				
Are the longitudinal standard spacing's correct?				
Are the transverse standard spacing's correct?				
Are the joints in standards correctly positioned?				
Are the joints in standards correctly secured (special duty or hung scaffold)?				
Are the ledgers level (or as designed)?				
Are the ledgers continuous (or as designed)?				
Are the lift heights correct?				
Are the horizontal ledger spacing's correct?				
Are the ledgers correctly secured?				
Are ledger joints correctly positioned (tube and coupler scaffold)?				
Are the joints in ledgers correctly secured (tube and coupler scaffold)?				
Are there sufficient transoms/putlogs?				
Are the transoms/putlogs correctly positioned and secured?				
Is the bracing adequate?				
Is the scaffold sufficiently stable?				
Are the ties correctly positioned and correctly fixed?				
<b>Platforms</b>	<b>Yes</b>	<b>No</b>	<b>NA</b>	<b>Remarks</b>
Does the scaffold have the required number of working platforms?				
Are the working platforms at the required locations?				
Are catch platforms correctly positioned?				
Are the platforms and supporting scaffold constructed for the appropriate duty live loads?				
Are the platform dimensions suitable for the intended work?				
Is there adequate edge protection?				

Are the platforms correctly constructed?				
Are planks secured against wind?				
<b>Containment Sheeting</b>	<b>Yes</b>	<b>No</b>	<b>NA</b>	<b>Remarks</b>
Has the scaffold been designed for wind loading on any containment sheeting?				
Are the fixing ties secure?				
Are there any rips or tears?				
Are the overlap joints satisfactory?				
<b>Mobile Scaffolds</b>	<b>Yes</b>	<b>No</b>	<b>NA</b>	<b>Remarks</b>
Is the supporting surface hard and flat?				
Is the area of operation free of floor penetrations, power lines and other hazards?				
Are the castor wheel locks in working order? (They should be locked at all times, except during movement of the scaffold).				

Annexure D

Lifecycle Diagram of Scaffolding

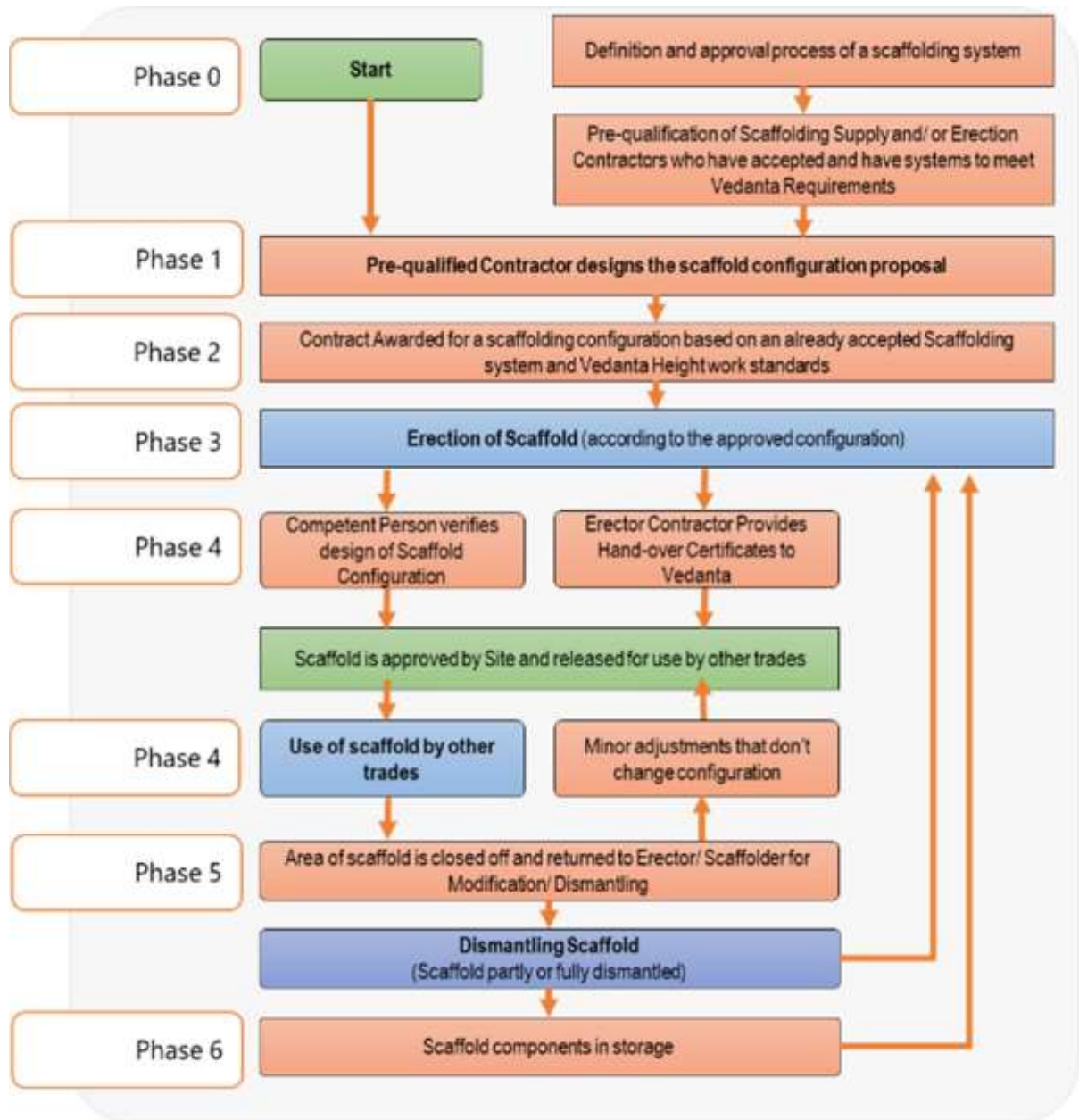

Phase Planning  
1

- Identify the work to be done.
  - Assess and evaluate the work to establish whether scaffold is the most appropriate option to complete the work, and, ensure that the risk of fall of people and/or objects are effectively managed.

<p>Phase 2</p>	<p>Design and selection of scaffolding configuration</p>	<ol style="list-style-type: none"> <li>1. folding configuration A scope of work that includes the following elements is provided to the Designer of the scaffold configuration:             <ul style="list-style-type: none"> <li><input type="checkbox"/> The intended use of the scaffold.</li> <li><input type="checkbox"/> The intended user group(s).</li> <li><input type="checkbox"/> The working environment of the scaffold.</li> <li><input type="checkbox"/> The intended duration of the scaffold.</li> <li><input type="checkbox"/> Any relevant cultural issues.</li> </ul> </li> <li>2. The selection of the scaffold system and the configuration should be compatible with the requirements of this scope of work.</li> <li>3. The scaffold design <b>MUST</b> provide for Fall Hazard Control (fall prevention and/or fall protection) at all times for all people exposed (including erectors, users and dismantlers). If this is not achievable, then alternative methods to scaffold must be used in conjunction with a reassessment of the task at hand.</li> <li>4. The design of Fall Hazard Control System(s) must be completed by a Competent Person and must be compatible with the scaffold configuration, the capability and competence of the user group, within the work environment. The following must be considered when designing the scaffold:             <ol style="list-style-type: none"> <li>a. When considering Fall Hazard Controls, always consider fall prevention before fall protection.</li> <li>b. The provision of fall prevention for the future users in the form of hand and knee rails and toe-boards.</li> <li>c. When deciding on Fall Hazard Control using Fall Arrest Systems, consider at least the following issues:                 <ul style="list-style-type: none"> <li><input type="checkbox"/> Adequate strength of the scaffold.</li> <li><input type="checkbox"/> Adequate stability (base soil/ground check, use of outriggers).</li> <li><input type="checkbox"/> Tie-off points to an external structure at every three (at least) levels (Unless prescribed differently by the designer).</li> <li><input type="checkbox"/> The scaffold erection and dismantling must be done under the supervision of a competent/qualified person and have regard to inclement weather conditions e.g., wind, lightning. All scaffold manufacturers’ instructions must be followed unless a safer method has been identified through a risk assessment and consultation with a Competent Person.</li> <li><input type="checkbox"/> When relying upon fall arrest for suspended and cantilever scaffold, tie off must be to an independent structure.</li> </ul> </li> <li>d. Consider using large floor mats (available as air bags or as textile mats).</li> </ol> </li> </ol>
----------------	--	---

		<p>e. To protect against accidental drowning – employ harnesses with a built-in personal floatation device (PFD) such as a life jacket.</p> <p>f. To protect against electrical contact:</p>
		<ul style="list-style-type: none"> <li><input type="checkbox"/> Apply the regulatory limits of proximity to energized conductor/equipment.</li> <li><input type="checkbox"/> Equip scaffolders with arc-fire proof clothing. <input type="checkbox"/> Employ special arc-fire proof blankets.</li> <li>g. When traffic (either personnel or materials) runs next to the scaffold, consider:             <ul style="list-style-type: none"> <li><input type="checkbox"/> Re-routing such traffic.</li> <li><input type="checkbox"/> Placing the warning pylons.</li> <li><input type="checkbox"/> Designating a traffic controller.</li> <li><input type="checkbox"/> Use of physical barriers to separate interaction with scaffold</li> </ul> </li> <li>h. When fall arresting is employed proven fall rescue procedures, equipment and trained personnel must be made available.</li> </ul> <p>5. design process must address energy sources that could result in le or multiple fatalities – and at a minimum must consider:</p> <p>sing</p> <p>Structural Collapse – of the scaffolding configuration and other structures</p> <ul style="list-style-type: none"> <li><input type="checkbox"/> e.g. due to ground conditions such as subsidence.</li> <li><input type="checkbox"/> Fires – internal and external to the scaffolding configuration.</li> <li><input type="checkbox"/> Vehicular – vehicles striking the structures/people.</li> <li><input type="checkbox"/> Gravitational – falling people and falling objects.</li> <li><input type="checkbox"/> Electrical – contact with an electrical source; and</li> <li><input type="checkbox"/> Chemical - drowning, toxins.</li> <li><input type="checkbox"/> Any other potential damaging energy e.g. wind, lightning, thermal or other.</li> </ul> <p>6. There should be a handover process from the Designer to the Erector/Dismantler/Scaffolder which includes the design limitations for the scaffold configuration and intended use.</p> <p>7. For Complex Scaffolds, the design should be verified by an independent Competent Person.</p> <p>8. Timber and bamboo should not be used in the frame of the scaffold.</p> <p>Selection of Scaffold System supplier and contractor</p> <ol style="list-style-type: none"> <li>1. Remuneration of the scaffolding contractor should not be driven by piecemeal rates (e.g. per rising metre).</li> <li>2. The scaffold supplier, should have a certified Quality Control Assurance Program that specifically pertains to the integrity of the scaffolding system which includes checks for wall thickness of scaffolding components.</li> </ol>



		3. Ensure scaffolder’s competency is current.
Phase 3 & 5	Erection/Dismantling (including modification)	<ol style="list-style-type: none"> <li>1. Erectors and dismantlers of scaffold MUST use the Fall Hazard Control System/s as specified in the design.</li> <li>2. A Vedanta representative should verify that Erectors and Dismantlers have incorporated those design features that specifically control the consequences of Multiple and Single Fatality as outlined in Phase 2, Stage 1.</li> <li>3. A Level 2 Risk Assessment (Job Hazard Analysis, Safe Work Method Statement) should be conducted for erection and dismantling and be specific to the scaffold configuration. This assessment should also be used to inform the necessary emergency response plan.</li> </ol>
		<ol style="list-style-type: none"> <li>4. Design considerations identified in the design phase shall be verified prior to use of the scaffold configuration.</li> <li>5. There MUST be a system for inspecting the scaffold configuration. The system must specify the criteria, accountabilities and frequency of inspection.</li> <li>6. Any modification from the original design of a complex scaffold configuration or scaffolding component must only be made by a Competent Person and must be subject to the Management of Change process.</li> <li>7. The activity of scaffold being erected, used or modified should also be captured within risk assessments of other activities/works within close proximity to where the activity of scaffold is taking place or impacted by the scaffold itself.</li> </ol>
Phase 4	Pre-use and use	<ol style="list-style-type: none"> <li>1. Verification that erected scaffold configuration meets the design configuration should occur before use of the scaffold. There should be evidence of this verification present at the scaffold (e.g., scaf-tag) which outlines its intended use and safe working load.</li> <li>2. Users of the scaffold configuration must use the Fall Hazard Control System(s) as specified in the design configuration.</li> <li>3. Prior to and when the scaffold configuration is in use there must be a formal inspection system. This system must include the criteria, accountabilities and frequency.</li> <li>4. The scaffold should only be used for its intended purpose and within its design limitations (as identified in the design scope).</li> </ol>
Phase 6	On site storage of scaffold	<ol style="list-style-type: none"> <li>1. The location and method for storing scaffold components on-site should be subject to a risk assessment having regard to the protection of the integrity of scaffold material (for future use) and ensuring the safety of those working in and around areas where scaffolding components may be stored.</li> <li>2. Scaffold that is used on site must be subject to quality management systems and processes and any specified maintenance requirements.</li> <li>3. When transporting scaffolding it must be secured to prevent movement when unloading and/or detaching the bundles for use or storage.</li> </ol>

Annexure E

Scaffold Hand-over Certificate

Certificate #:

Erection Supervisor: Contractor/ Supplier		Designated Scaffolding Supervisor: Vedanta	
Name : Signature:		Name : Signature:	
Company Name & Address:		Location and Site Address:	
Contact Phone:		Contact Phone:	
Project Details:			
Project/Reference number:			
Description of area handed over:			
Drawings attached? (Provide details):			
Intended use of scaffold:			
Number of working decks (lifts fully planked with full edge protection):			
Ladder/ Stair Access bays to all working lifts:			
Screening:			
Top working platform height :			
Duty Classification of the Scaffold			
Light duty (225 kg per bay)	Useable lifts per bay	Limitations: _____	

## Guidance Note – Scaffolding Safety

Medium duty (450 kg per bay)	Useable lifts per bay	_____
		_____
Heavy duty (675 kg per bay)	Useable lifts per bay	_____
		_____
Special duty	Useable lifts per bay	_____
		_____

### Annexure F

#### Additional Guidance on Creating a Scaffolders Safe Zone

To assist employers, when completing their risk assessment and selecting the most appropriate method of creating the scaffolders' safe zone for the task, a range of established proven solutions are featured in this section. These established systems of work protect scaffolders whilst creating the scaffolders' safe zone and include:

- Tools for installing guardrails in advance
- Proprietary advanced guardrail equipment
- Use of special personal protective equipment
- Methods of work without specialist equipment

Some of these innovative methods of work provide the same levels of collective fall protection as similar proprietary products, but utilise standard scaffolding materials without the need to invest in specialist equipment (e.g. short-lift method).

## Guidance Note – Scaffolding Safety

### Scaffolders' step

This popular system utilises a proprietary step that is fixed to the main guardrail approximately 1m above the working platform. This enables the scaffolder to erect the guardrail protection on the lift above in advance or remove them from below during dismantling (Figure 66, 67 and 68).

The sequence of work needs to be considered when using some older designs of scaffolders' step, as ledger bracing or stop-end guardrails may impede their use. Therefore, these items may need to be fixed after the guardrails have been erected in the lift above with scaffolders using personal fall protection equipment (safety harnesses), where necessary.

**IMPORTANT :** Scaffolders must be clipped onto a suitable anchor point, ideally to the back ledger, due to the risk of falling from the scaffold when using a scaffolders' step system. Scaffolders must be clipped on before climbing on the temporary platform and must not jump down onto the boarded platform due to the risk of board failure from impact loads.



Figure 66: Scaffolder installing a guardrail in advance to the next lift from a scaffolders' step protected by the ledgers and transoms

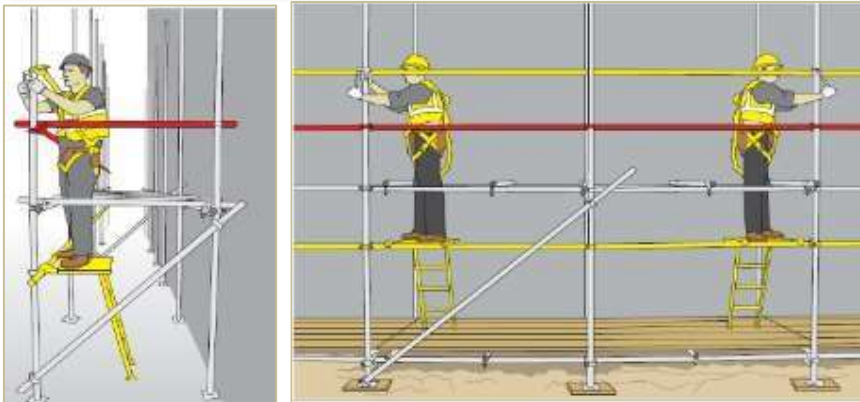

Figure 67: Shows the scaffolders' step being used with an additional guardrail to the base lift (Left) & boarded base lift to support the step on uneven ground (Right)

For some modular system scaffolding, standard side brackets (hop-ups) can be used to create an internal temporary platform to install guardrails in the lift above, in a similar fashion to the proprietary scaffolders' step system.

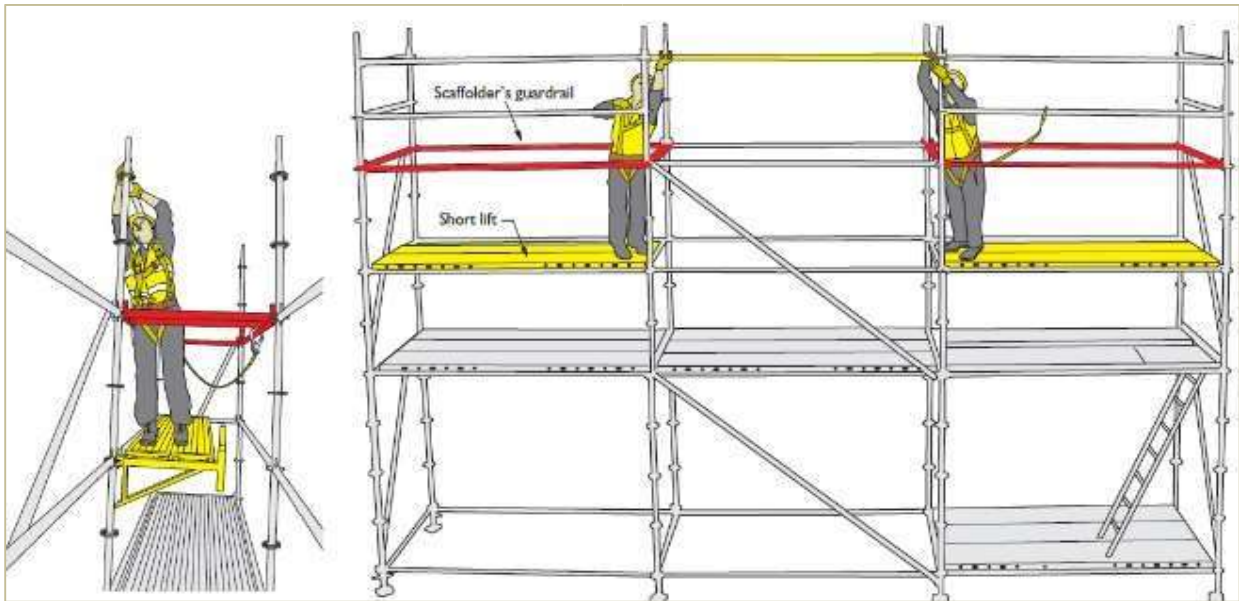

Figure 68: Systems scaffolds slide brackets used to create scaffolders' step platform in alternate bays. The middle bays can be reached from adjacent bay to fix the guardrails

#### Push up advanced guardrail tool

This push up type advanced guardrail tool (AGT) utilises special couplers that allows scaffold tube guardrails to be erected from below and pushed up into position with a locating tool (see Figure 69). The guardrail is automatically locked and remains in place to provide fall protection when scaffolders access the next lift. The sequence of work is critical as the advance guardrails need to be raised before the next lift is formed. The temporary guardrail remains in place whilst the permanent guardrails are fitted.

Alternatively, the AGT couplers can be replaced with normal right-angle scaffold couplers to form the scaffold guardrails. This system can be used on all faces of the scaffold including inside fall risks and stop-ends. The positioning tool is also used to unlock the guardrail from below during dismantling. This system is primarily suited for traditional tube and fitting scaffolds.

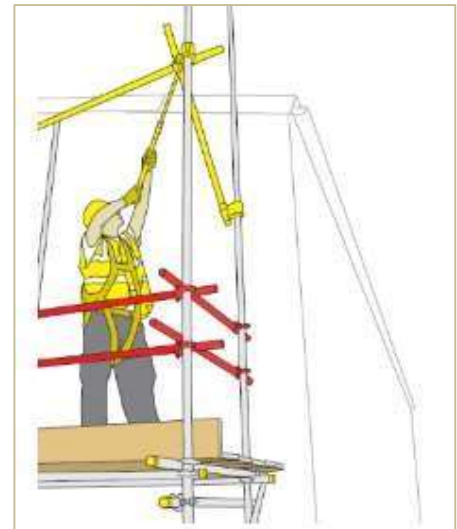
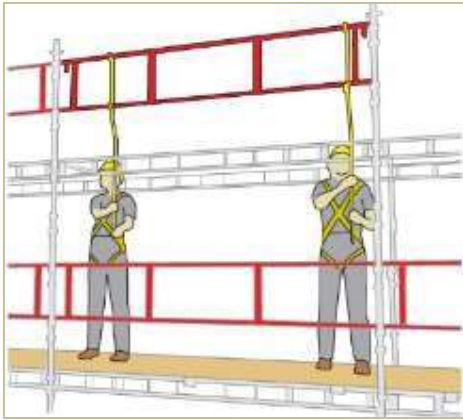

Figure 69: Push type Advanced Guardrail Tool (AGT) using special couplers and positioning tool



Some proprietary system scaffold manufacturers provide advanced guardrail tools that are bespoke to their particular product (see Figure 70). Special arms are used to locate/remove the guardrail frame in the lift above.

Figure 70: Example of a system scaffold-specific advanced guardrail tool

### Proprietary Advanced Guardrail Systems (AGS)

Several proprietary collective fall protection systems are available and have become known as ‘Advanced Guardrail Systems’ (AGS) (see Figure 71).

Advanced guardrail systems provide collective fall prevention for scaffolders when traversing along a boarded lift, erecting, altering or dismantling scaffolding. These temporary guardrails remain in place whilst the platform guardrails are installed or removed, allowing scaffolders to maintain guardrail edge protection on working platforms at all times.

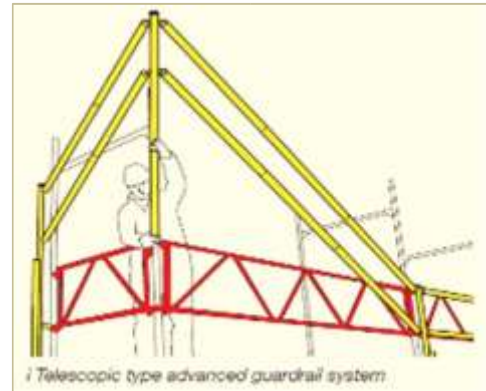

Figure 71: Telescopic type Advanced Guardrail System

The suitability of advanced guardrail systems needs to be considered as part of the risk assessment process when planning work at height and included in the method statement. These systems are best suited to straight

uniform scaffold structures without complex elements e.g. long straight facades with minimum returns, recesses or protrusions. Where an AGS is pushed up the outside of the structure, their operation can be impeded by protrusions from the scaffold or façade. Scaffolders may have to ensure that the transoms, ledgers, bracing etc. are correctly sized so that they do not have excessive overhang.



Figure 73: Horizontal type AGS

Where there exists a risk of a fall to the inside face of the scaffold, scaffolders may need to change the normal sequence of work to accommodate the AGS e.g. locate the AGS above, before fixing transoms, hop-up brackets or tie assemblies (see Figure 72).

Figure 72: Shows the modified sequence of erection to allow ‘push-up’ AGS’ to be used on the inside face before fixing transoms, ties or hop-up inside board brackets above





The horizontal type AGS (see Figure 73) is best suited to independent tied scaffolding (façade scaffolds), because it pushes along the lift, fixes to the standards and can provide protection to both inside and outside faces of the scaffold. To provide full collective protection it must be used in conjunction with an additional AGS that can be fixed/removed from below for the first bay during erection and the last bay when dismantling. Again, additional precautions need to be taken at stop-ends or corner returns.

Some manufacturers of proprietary system scaffolding have developed an integrated AGS that form the permanent guardrails for the completed scaffold structure (Figure 74)

The suitability of advanced guardrail systems needs to be considered as part of the risk assessment process when planning work at height and included in the method statement. These systems are best suited to straight uniform scaffold structures without complex elements e.g. long straight facades with minimum returns, recesses or protrusions.

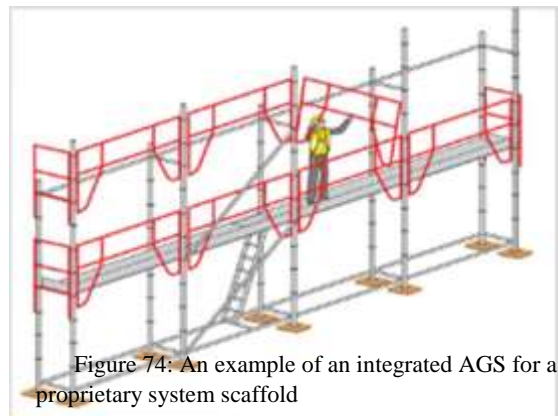
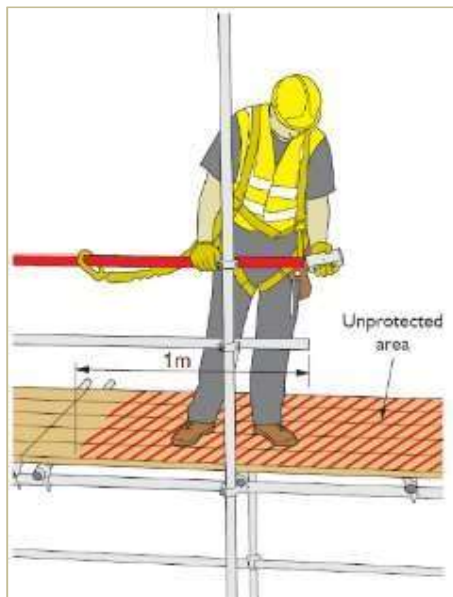

Figure 74: An example of an integrated AGS for a proprietary system scaffold



## Protected Traversing

When utilising this system of work, to create a scaffolders' safe zone, then suitable compensatory measures must be taken that minimise the distance and consequences of a fall.

In practical terms scaffolders **MUST** be continually clipped on to a suitable anchor point when exposed to the risk of a fall whilst working outside (or within 1 metre of the end) of guardrail protection (see Figure 75).

Figure 75: A scaffolder exposed to risk of falling at a leading edge (within 1 metre from the edge of the Scaffolders' Safe Zone).



To minimise the potential fall distance it is preferable for scaffolders to utilise anchor devices that fix to the standard above (ideally the inside standard furthest from the edge) rather than the ledger below foot level (see Figure 76).

Figure 76: Special snap-hooks for anchoring onto the vertical scaffold tubes

In order to traverse along an unprotected platform, a minimum system of work would be required utilising double or twin-tailed lanyards (See Figure 77 below).



To traverse, double lanyards are used to remain continually attached, ideally to inner standard or ledgers

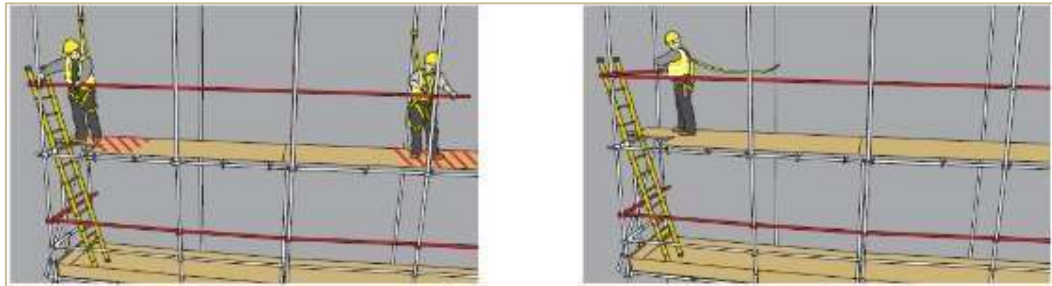

Progressively install guardrails remaining continually attached to create the 'Scaffolders' Safe Zone'

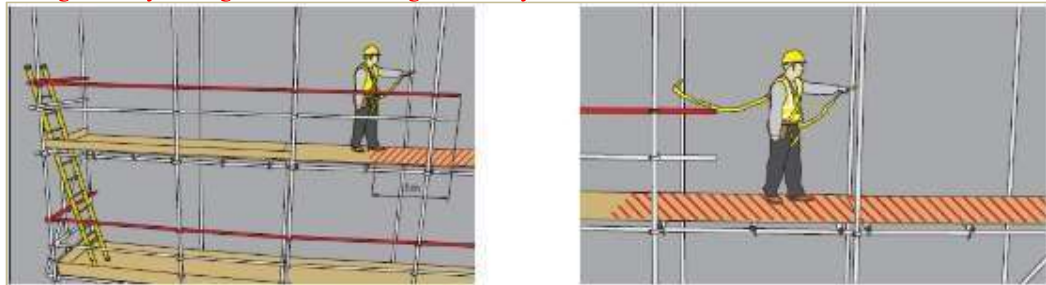

Attach fence roaching within 1m of the end of the protected Scaffolders' Safe Zone

The process is repeated, progressively installing guarding to create the 'Scaffolders' Safe Zone' whilst remaining continually attached

Figure 77: Protected Traverse sequence of work using double lanyards attached to standards

Short Lift System

To use the short-lift system of work, the ledgers and transoms of the next lift are erected as normal to form a main lift (e.g. 2m above the current lift). Then a temporary intermediate 1m high short-lift is formed (also referred to as a dummy lift). Therefore, as the scaffolders access the next 1m level, the ledgers and transoms are already in place and act as guardrails to provide collective fall protection (see Figure 78). Decking on the temporary short-lift can be raised to the next lift and any temporary transoms required can be removed later

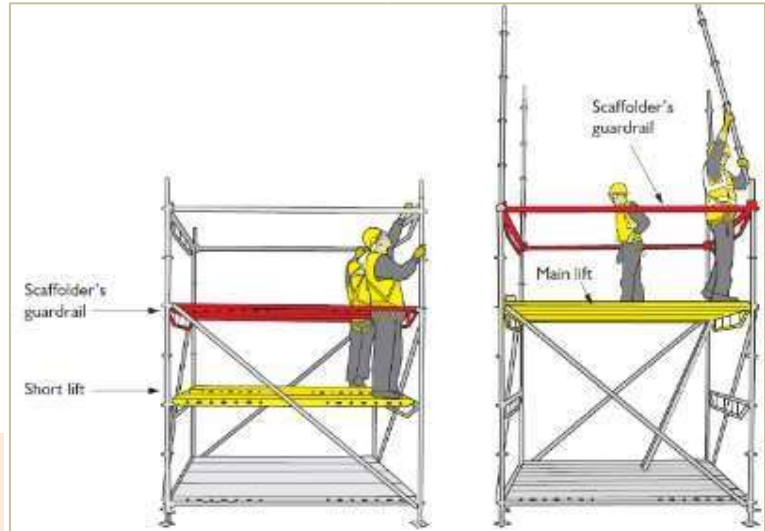

Figure 78 This sequence shows the short-lift system used to erect a system scaffold tower

to provide clear access on all working lifts for other trades.

This system of working can be used on all scaffolds with conventional lift heights of up to 2.1m, however it is best suited to scaffolds designed without ledger bracing (e.g. modular system scaffolds or prefabricated transom units used in accordance with the manufacturer's instructions and TG20). System decking also eliminates the need to install temporary intermediate transoms as board bearers. However, suitable methods of access and egress between the main lifts of the scaffold must still be used.

Tube and fitting frame type AGS

Tube and fitting frame type advanced guardrail system (AGS) functions similarly to proprietary advanced guardrail systems.

**Step 1:** Select materials to suit the length of the scaffold elevation and bay sizes to be protected. The uprights are formed with 2.7 metre or 3 metre (9ft or 10ft) scaffold tubes, and a single tube is used to form the temporary guardrail. Aluminium tube can be used to reduce the handling weight. **Step 2:** Lay out the tubes on the ground to form a 'goal post' frame. Then fix the guardrail to the end of the upright tubes using right-angle couplers

**Step 3:** Now fix a second right-angle coupler to each upright tube. Measure 1100mm down from the centre of the top coupler. Note that these couplers must be to the opposite side of the tube and fixed 'up-side-down' (see Figure 79).



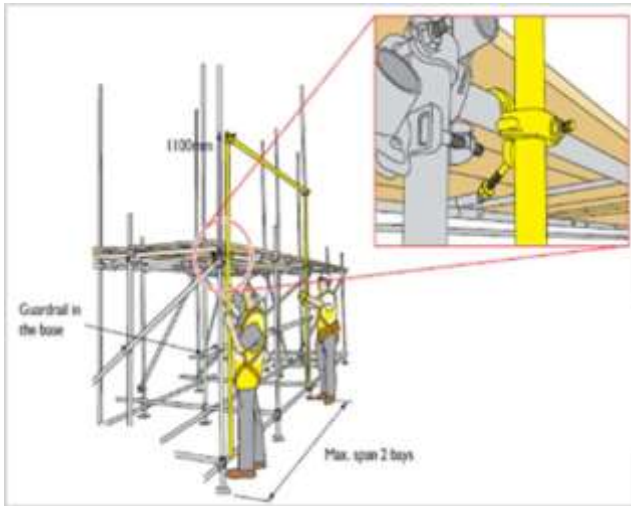

Step 4: Using two scaffolders, lift the frame and fix to the ledge. Note, by fixing the coupler ‘up-side-down’ it will support itself until secured. Also note that an additional guardrail is required for the base lift only for the vertical tube to act against.

Step 5: Couplers can now be secured to fix the advanced guardrail in place. Scaffolders can now access the platform and erect the next lift once the AGS is in place.

Step 6: When the permanent guardrails have been installed, the advanced guardrail can be raised to the next level. This is more easily achieved by pulling back the outside board to access the coupler, from above.

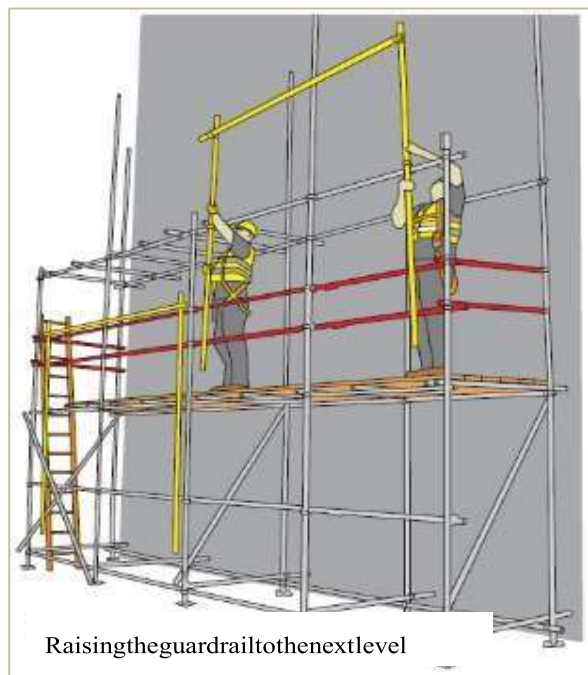
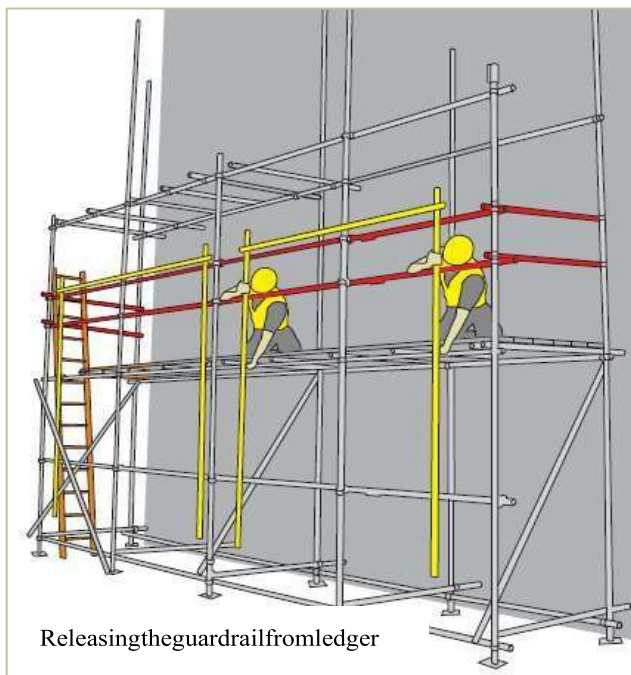

Figure 79: AGS frame constructed on the ground and fixed to the base lift

Where tie assemblies, transoms for inside boards, buttresses or other protrusions may obstruct the raising of the advanced guardrail, the build sequence will be critical, ensuring the advanced guardrail is raised prior to the transoms etc. being installed. If the advanced guardrail is obstructed by the façade bracing, then fix the brace once the advanced guardrail has been raised.

This advanced guardrail system can also be used for dismantling and alterations that necessitate the removal of guardrail protection.



## Guidance Note – Scaffolding Safety

### Tube and fitting horizontal type AGS

Functions similarly to proprietary horizontal type systems. Other forms of protection must be used to create the scaffolders' safe zone for the first bay.

Step 1: Working from behind the guardrail protection, fix two right-angle couplers to the standards above the existing guardrail.

Step 2: Using another tube to form a temporary guardrail, place it loosely into the two fittings so the tube can still slide horizontally.

Step 3: Push the tube out horizontally past the next standard (one bay max) and tighten the end coupler.

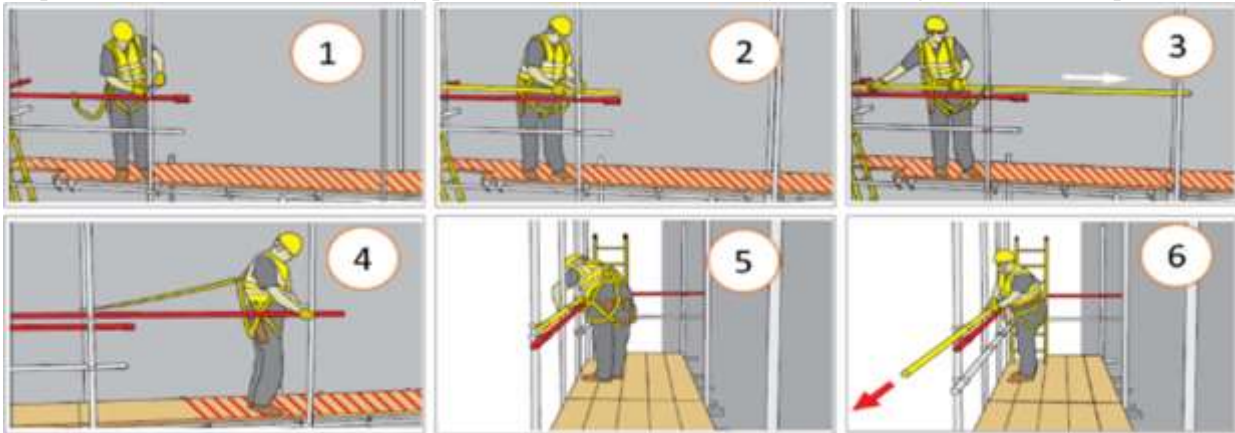

Figure 80: Work Sequence for Installing Horizontal tube and fitting type AGS

Step 4: Now walk out to fix the temporary guardrail to the standard, clipping on until the guardrail is secured and if encroaching within 1m of the end.

Step 5: The working platform guardrail(s) can now be completed and next lift constructed with the scaffolders' safe zone in place.

Step 6: The temporary guardrail can then be released and slid along horizontally to the next bay. This sequence is repeated one bay at a time to provide the scaffolders' safe zone.

### Special Work Situations

#### Shorter Lifts

Progressive scaffolds for brickwork are normally erected using 1.35 – 1.5 metre lift heights. Many of the established collective fall protection systems do not easily accommodate these smaller lift heights. In such cases the scaffolders' step or small proprietary standings may be used to enable scaffolders to install guardrails in advance to the next lift. The intermediate guardrail can often be fixed simply from the lift below as they are typically only 1.75 to 2 metres above the lift (see Figure 90 below).

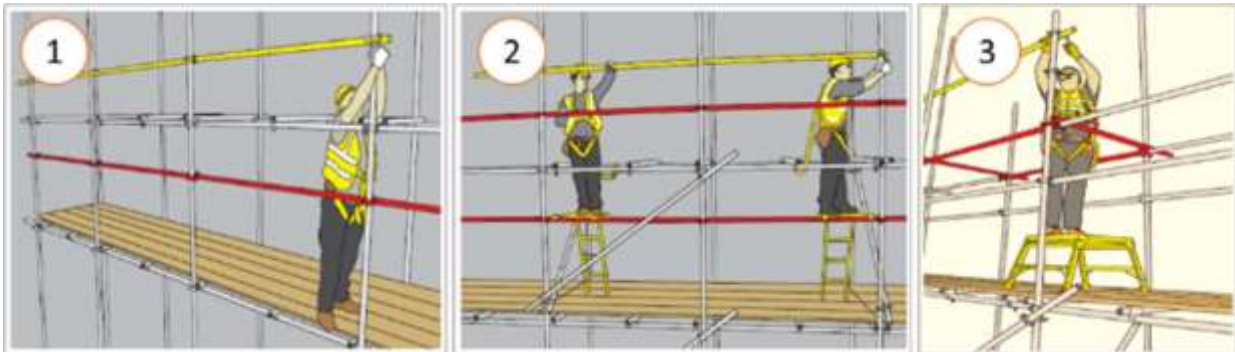

Figure 90: Example of a sequence of work used to erect guardrails in advance for shorter lift heights. (1) the intermediate guardrail installed from the lift below; (2) scaffolders' step used to install the main guardrail and (inset) showing stop-end guardrail; and (3) mm proprietary staging platform being used as an alternative step-up.

Tall lifts (Floor Height Lifts, Pavement Lifts and Gantries)

Scaffolding with taller lift heights such as the erection of pedestrian base lifts (up to 2.7 metres) or floor height lifts (up to 3 metres) are often difficult to provide collective fall protection for, as most of the common systems of work are designed for a standard 2 metre lift height only. Scaffolders may have to use a combination of systems to achieve full collective protection for taller lifts. For example, using the 'short lift method' (or dummy lift) at approximately 1 metre and then resorting to other safe methods to install guardrails on the working platform (see Figure 97).

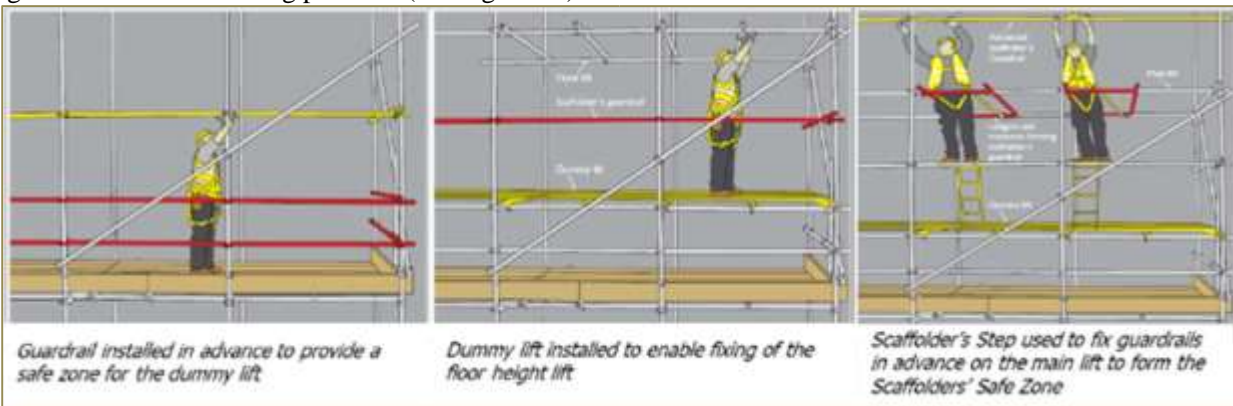

Figure 91: Work Sequence for Installing Horizontal tube and fitting type AGS

The dummy lift can then be dismantled to allow unimpeded access on the working lift during use of the scaffolding, but should be reinstated for any alterations and dismantling. Note that temporary guardrails should be left in place where possible for dismantling.

## Guidance Note – Scaffolding Safety

Alternatively, floor height lifts can be constructed by splitting the lift height into a conventional 2 metre lift and a shorter lift which can remain in place throughout the works.

Where scaffolders' steps are used to install taller lifts (as opposed to fixing guardrails in advance) guardrails should be installed to prevent falls from the step from the scaffolding and scaffolders must remain clipped-on (see Figure 92).

Figure 92: Scaffolders' Safe Zone in case of tall lifts (1) Scaffolder using scaffolders' steps to form floor height; and (ii) Podium used as an alternative for taller lift heights

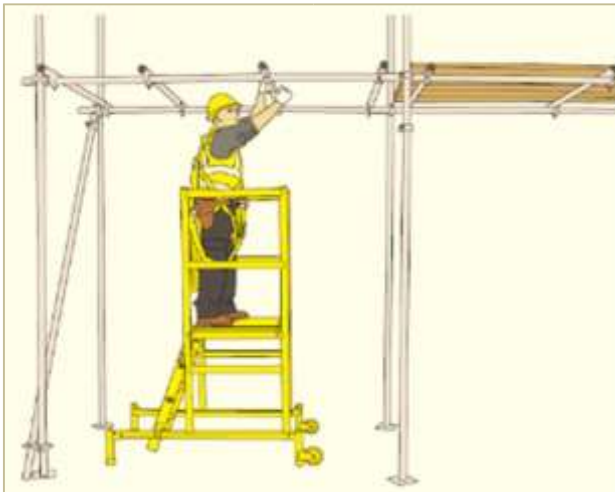
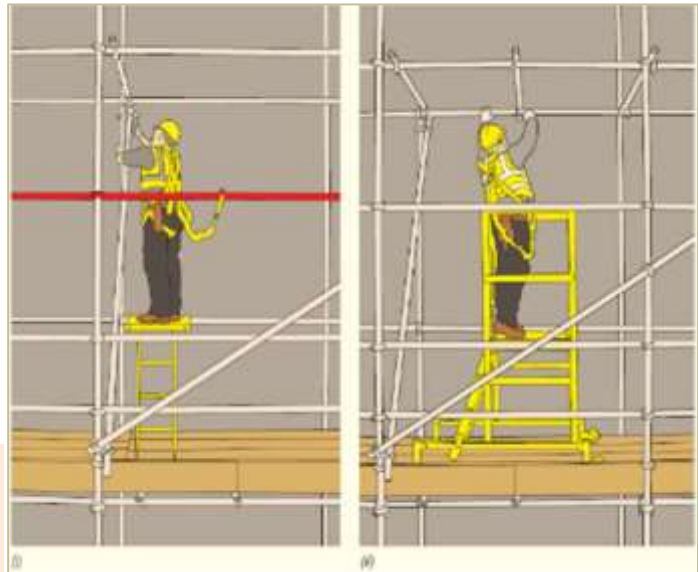

Figure 93: A podium scaffold used to erect a pavement lift

The use of a podium step or mobile access tower (as shown in Figure 93) is one example for erecting/ dismantling tall base lifts providing the ground condition is suitable.

### Protection fans and Cantilevered Structures

The construction of protection fans and other cantilevered structures requires scaffolders to fix the needles or beams from the main scaffold (back or horse scaffold) and typically relies on the use of personal fall protection equipment (safety harnesses, preferably with inertia reels) solely for completing the structure. See Figure 94.



Figure 94: Falling object protection fan erected using an inertia reel

## Guidance Note – Scaffolding Safety

In some cantilevered scaffolding applications (e.g. truss-out scaffolding) it may be possible to push out the cantilever from the protection of the main scaffold a guardrail assembly, in advance, to provide a temporary guardrail and form a scaffolders' safe zone (Figure 95).

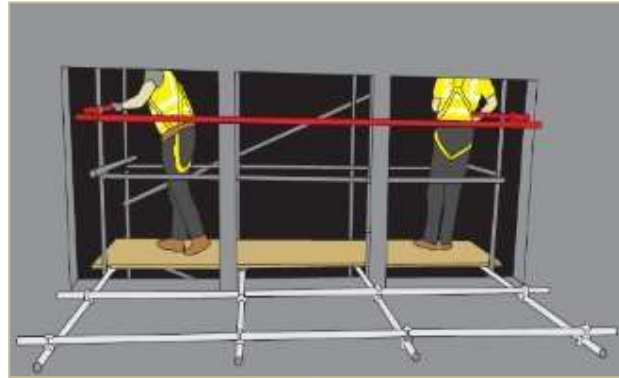

(i). Temporary guardrail formed from the back scaffold (horse or support scaffold) within a scaffolders' safe zone.

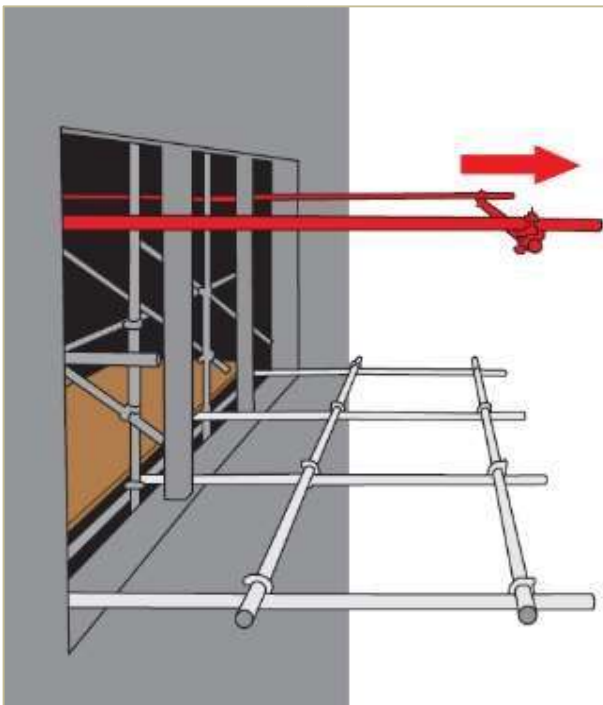

(ii) Guardrail pushed out horizontally from the back scaffold to protect the truss-out.



(iii) Needles are boarded out to create a scaffolders' safe zone to complete the truss-out scaffold.

Figure 95: An example of a temporary guardrail assembly used to provide a scaffolders' safe zone during the erection of a truss-out cantilevered scaffold.

### Temporary Handrails on Under-construction Stairways



Another common challenge facing scaffolding contractors is the safe erection of temporary handrails for the installation of permanent stairways in construction. Pre-cast concrete staircases manufactured to accommodate handrail posts that can be installed on the ground prior to them being craned into place, can eliminate or minimise the need for scaffolders to work at height.

## Roof Works

Erecting edge protection to existing roofs can be particularly problematic for scaffolders to provide safe systems of work, especially if MEWP access is not possible or there is an absence of suitable anchor points for using personal fall protection equipment. In such cases, scaffolders may need to rely upon mobile anchor devices, fall restraint systems or work positioning equipment (for further guidance reference should be made to BS 8437 Code of practice for selection, use and maintenance of personal fall protection systems and equipment for use in the workplace).

Occasionally scaffolders need to access or work on roofs, where there is a risk of a fall through a fragile surface, such as cement roof sheets or fragile roof lights. Scaffolders should be provided all available information regarding fragile roof surfaces to the scaffolding contractor. Scaffolders must not walk on or next to fragile materials unless fall prevention or fall mitigation measures (Figure 96) are in place and used.



Figure 96: Scaffolder utilizing an installed protection system for roof

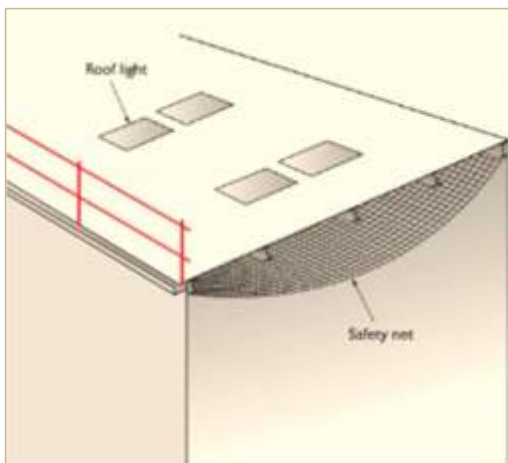

Figure 97: Fall arrest netting rigged to protect against fall through a fragile roof light

These include one or a combination of; barriers, covers, crawling boards, horizontal line or rope grab harness anchor systems. Where it is not practical to cover the fragile materials, fall arrest safety nets or similar collective protection could be rigged to the underside of the structure to protect against any such fall (Figure 97). Where collective fall arrest systems are chosen, they must be installed in accordance with manufacturers' instructions and any recognised training scheme.

Where existing permanently-installed fall protection systems are available for roof access then these should be utilised, where possible. It must be ensured they are used in accordance with the manufacturers' instructions, including checking maintenance and inspections records before use.

## Guidance Note – Scaffolding Safety

### False-work, Formwork and Other Temporary Structures

The main focus of this guidance is aimed towards access scaffolding, however the basic principles of this guidance can be applied, where scaffolders construct other similar temporary structures in scaffolding or proprietary systems (e.g. false-work, formwork, stages, seating, bridging etc. ).

Collective fall protection methods (e.g. the scaffolders’ safe zone), anchor points for attaching personal fall protection equipment and methods of access and egress must be considered by designers and employers at planning stage.

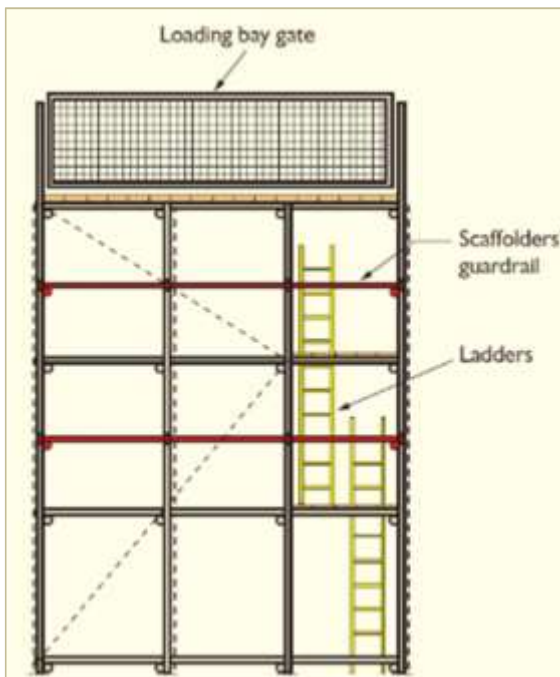

**Figure 99:** A stand alone loading tower with access built in and left for dismantling purpose only. After erection, access to the ladders should be controlled.

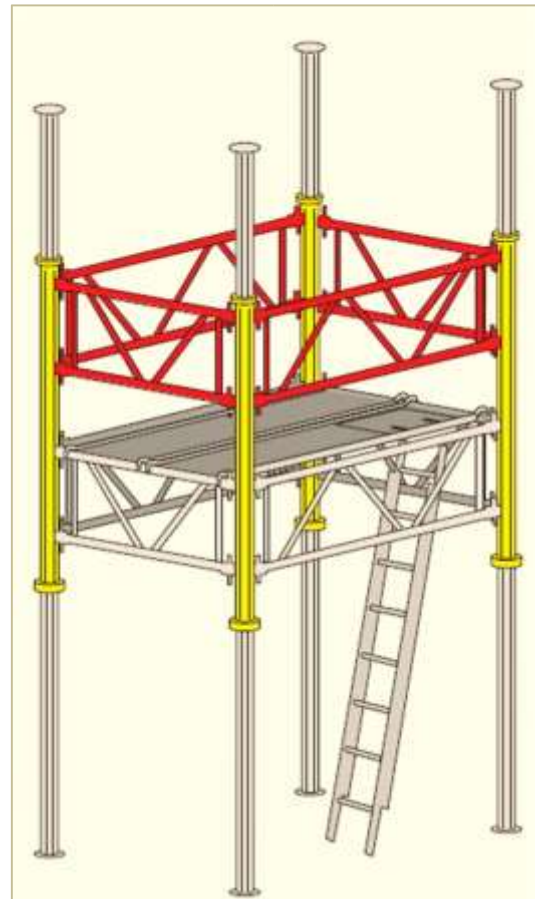

**Figure 98:** Fully decked and guardrailed working platform to form a scaffolders’ safe zone with safe access and egress, used for the erection, alteration and dismantling of a formwork system.

These special scaffold structures that do not normally include a method of access (e.g. false-work, shoring, loading bays etc.). Hence special consideration must be given in the planning process for the use of ladders etc. to avoid climbing the structure wherever possible (Figure 99).



